



The Space Shuttle's Return to Flight: Mission STS-114 Press Kit



A Step Into The Future



CONTENTS

SECTION I: SPACE SHUTTLE SAFETY ENHANCEMENTS

OVERVIEW	1
RETURNING THE SPACE SHUTTLE TO FLIGHT	1
IMPROVEMENTS IN TECH EXCELLENCE, COMMUNICATIONS & DECISION-MAKING	3
NASA ENGINEERING AND SAFETY CENTER	8
SPACE FLIGHT LEADERSHIP COUNCIL	3
RETURN TO FLIGHT TASK GROUP (STAFFORD-COVEY)	4
SPACE SHUTTLE PROGRAM MISSION MANAGEMENT TEAM	5
THE MISSION MANAGEMENT TEAM:	7
NASA ENGINEERING AND SAFETY CENTER	8
RENEWED COMMITMENT TO EXCELLENCE.....	9
SPACE SHUTTLE PROCESSING IMPROVEMENTS.....	11
REINFORCED CARBON-CARBON WING PANELS AND NOSE CAP	11
WING LEADING EDGE STRUCTURAL SUBSYSTEM	12
RUDDER SPEED BRAKE	12
FOREIGN OBJECT DEBRIS.....	13
CLOSEOUT PHOTOGRAPHY PROCESS	15
LAUNCH PAD GROUND SUPPORT EQUIPMENT	17
FIXED AND ROTATING SERVICE STRUCTURES.....	17
UPPER HINGE COLUMN BEARING.....	18
GASEOUS OXYGEN VENT ARM (“BEANIE CAP”).....	18
GASEOUS HYDROGEN VENT ARM	18
CRAWLER TRANSPORTER	18
RECOGNIZING & ELIMINATING CRITICAL SHUTTLE DEBRIS SOURCES.....	21
PREPARING THE EXTERNAL TANK	21
BIPOD REDESIGN	22
LIQUID HYDROGEN (LH2) INTERTANK FLANGE.....	24
LIQUID OXYGEN (LO2) FEEDLINE BELLOW.....	24
PROTUBERANCE AIR LOAD (PAL) RAMPS	25

ENHANCED IN-FLIGHT IMAGERY	26
NON-DESTRUCTIVE EVALUATION (NDE)	26
THERMAL PROTECTION SYSTEM CERTIFICATION	27
THERMAL PROTECTION SYSTEM (TPS) VERIFICATION & VALIDATION	27
SOLID ROCKET BOOSTER MODIFICATION	29
BOLT CATCHER	29
BOOSTER SEPARATION MOTOR IGNITER	30
IDENTIFYING, INSPECTING AND REPAIRING TPS DEBRIS DAMAGE IN FLIGHT	33
IMPROVING IMAGERY, DATA COLLECTION FOR SPACE SHUTTLE LAUNCH AND LANDING	33
GROUND-BASED IMAGING OF LAUNCH	33
CAMERAS	35
CAMERA LOCATIONS	36
CAMERA RESOLUTION	37
CAMERA OPERATIONS PLAN	37
TAKING THE HIGH GROUND ON ASCENT IMAGING	38
RADAR TRACKING	39
WING LEADING EDGE INSTRUMENTATION	40
ENHANCED SHUTTLE-BASED CAMERA VIEWS	43
EXTERNAL TANK-MOUNTED CAMERA	44
SOLID ROCKET BOOSTER CAMERAS	46
EXTERNAL TANK UMBILICAL WELL DIGITAL STILL CAMERA	47
CREW HANDHELD PHOTOGRAPHY	48
DIGITAL SPACEWALK CAMERA	49
IN-FLIGHT INSPECTION AND REPAIR	50
THERMAL PROTECTION SYSTEM ON-ORBIT REPAIR TECHNIQUES	52
TILE	55
REINFORCED CARBON-CARBON	57
ACCESS	58
FUTURE WORK	58
CONTINGENCY SHUTTLE CREW SUPPORT (CSCS) – SAFE HAVEN (CSCS)	59
CAIB RECOMMENDATIONS	61

SECTION II: THE STS-114 MISSION

STS-114 MISSION OVERVIEW	65
STATION RESUPPLY HIGHLIGHT DISCOVERY'S MISSION	65
TIMELINE OVERVIEW.....	67
MISSION OBJECTIVES	73
LAUNCH AND LANDING	75
LAUNCH.....	77
ABORT-TO-ORBIT (ATO) –.....	77
TRANSATLANTIC ABORT LANDING (TAL) –.....	77
RETURN-TO-LAUNCH-SITE (RTL) –.....	77
LANDING	78
MISSION PROFILE.....	77
DISCOVERY CREW – STS-114	79
KEY MISSION PERSONNEL	83
RENDEZVOUS AND DOCKING	85
UNDOCKING, SEPARATION AND DEPARTURE.....	90
SPACEWALKS	89
EVA 1.....	91
EVA 2	98
EVA 3	99
PAYLOAD OVERVIEW	101
RAFFAELLO MULTI-PURPOSE LOGISTICS MODULE.....	102
EXTERNAL STOWAGE PLATFORM-2.....	102
MATERIALS INTERNATIONAL SPACE STATION EXPERIMENT (MISSE).....	103

EXPERIMENTS (DTOS AND DSOS)	105
DETAILED SUPPLEMENTARY OBJECTIVES	
DSO 206 - EFFECT OF SPACE FLIGHT ON BONE, MUSCLE AND IMMUNE FUNCTION(PRE/POST FLIGHT ONLY)	107
DSO 490B - BIOAVAILABILITY AND PERFORMANCE EFFECTS OF PROMETHAZIN E DURING SPACE FLIGHT, PROTOCOL B.....	107
DSO 493 - MONITORING LATENT VIRUS REACTIVATION AND SHEDDING IN ASTRONAUTS.....	107
DSO 498 - SPACE FLIGHT AND IMMUNE FUNCTION (PRE/POST FLIGHT ONLY)	108
DSO 499 - EYE MOVEMENTS AND MOTION PERCEPTION INDUCED BY OFF-VERTICAL AXIS ROTATION (OVAR) AT SMALL ANGLES OF TILT AFTER SPACEFLIGHT (PRE/POST FLIGHT ONLY).....	108
DSO 500 - SPACE FLIGHT INDUCED REACTIVATION OF LATENT EPSTEIN-BARR VIRUS (PRE/POST FLIGHT ONLY)	108
DSO 504 - MICROGRAVITY INDUCED CHANGES IN THE CONTROL OF MUSCLES (PRE/POST FLIGHT ONLY)	109
DETAILED TEST OBJECTIVES	
DTO 805 - CROSSWIND LANDING PERFORMANCE (DTO OF OPPORTUNITY).....	109
DTO 848 - ORBITER THERMAL PROTECTION SYSTEM (TPS) REPAIR TECHNIQUES	110
DTO 850 - WATER SPRAY BOILER COOLING WITH WATER/PGME ANTIFREEZE	110
SHUTTLE REFERENCE DATA	109
SHUTTLE ABORT MODES.....	111
RSLs ABORTS	111
ASCENT ABORTS	111
INTACT ABORTS.....	111
RETURN TO LAUNCH SITE.....	111
TRANSOCEANIC ABORT LANDING.....	112
ABORT TO ORBIT.....	112
ABORT ONCE AROUND	112
CONTINGENCY ABORTS.....	113
ABORT DECISIONS	113
SHUTTLE ABORT HISTORY.....	114
RSLs ABORT HISTORY: (STS-41 D) JUNE 26, 1984	114
(STS-51 F) JULY 12, 1985	114
(STS-55) MARCH 22, 1993.....	114

(STS-51) AUG. 12, 1993	114
(STS-68) AUGUST 18, 1994	114
ABORT TO ORBIT HISTORY: (STS-51 F) JULY 29, 1985	114
SPACE SHUTTLE MAIN ENGINES	114
SPACE SHUTTLE SOLID ROCKET BOOSTERS	116
HOLD-DOWN POSTS	118
SRB IGNITION	118
ELECTRICAL POWER DISTRIBUTION	119
HYDRAULIC POWER UNITS	119
THRUST VECTOR CONTROL	120
SRB RATE GYRO ASSEMBLIES	121
SRB SEPARATION	121
SPACE SHUTTLE SUPER LIGHT WEIGHT TANK (SLWT)	121
ACRONYMS AND ABBREVIATIONS	121
MEDIA ASSISTANCE	131
MEDIA CONTACTS (PUBLIC AFFAIRS CONTACTS)	133

"This cause of exploration and discovery is not an option we choose; it is a desire written in the human heart..."

– President George W. Bush, Feb. 4, 2003

RETURNING THE SPACE SHUTTLE TO FLIGHT



NASA will return Space Shuttles to flight with a mission on the Shuttle Discovery this spring. The crew of seven is charged with a busy to-do list, including testing new safety techniques and delivering much-needed supplies to the International Space Station. Discovery's launch is targeted for May 22 with a launch window that extends to June 3, 2005.

But Return to Flight is more than a single mission. It launches a new era of human exploration that's far-reaching but focused, ambitious but affordable. Return to Flight illustrates NASA's ability to learn from mistakes and its determination to prevent new ones. And it pays tribute to a crew of seven brave astronauts on the Space Shuttle Columbia, who two years ago gave their lives in the pursuit of the knowledge that comes from exploration.

Following the Columbia accident on February 1, 2003, the independent [Columbia Accident Investigation Board](#) conducted a thorough, seven-month inquiry. The CAIB issued its findings and recommendations in August 2003, in a comprehensive report.

The board determined that the physical cause of the accident was a breach in the Shuttle's left-wing leading edge caused by a piece of insulating foam that fell off the External Tank during the climb to orbit. This foam block, weighing approximately 1½ pounds and about the size of a suitcase, struck a portion of the wing covered in a dark, grey substance called

Reinforced Carbon-Carbon, part of the Shuttle's heat-shielding Thermal Protection System. The damage allowed superheated air to penetrate the wing's interior and to weaken the structure, eventually causing Columbia's breakup 40 miles above central Texas, 16 minutes before landing.

Even before the CAIB final report laid out 15 recommendations to be completed before Space Shuttle missions could resume, the agency began the process of returning the Shuttle to safe flight by forming a team to plan for Return to Flight. The resulting document – reviewed and updated as those recommendations are addressed – is called NASA's Implementation for Space Shuttle Return to Flight and Beyond.

NASA did not stop by addressing only the 15 recommendations specified to be implemented prior to flying the Space Shuttle again. Another 14 recommendations from the Board are being implemented as well by NASA.

Additionally, the agency has gone above and beyond the CAIB recommendations with a list of 15 corrective actions known as "Raising the Bar" to make the Space Shuttle safer than it has ever been.

These initiatives combined mean NASA is addressing 44 issues leading to Return to Flight.

An independent group was formed by the NASA Administrator to evaluate how NASA is addressing the CAIB recommendations. This [Return to Flight Task Group](#) is conducting an independent assessment of NASA's implementation of those recommendations as they relate to the safety and operational readiness of Space Shuttle Discovery's upcoming mission, designated STS-114.

With long-range planning in the form of the [Vision for Space Exploration](#) announced in January 2004, the agency is beginning a new chapter in its history. It is recommitting itself to excellence in all aspects of its programs by strengthening its culture and improving technical capabilities.

Space Shuttle Columbia and its seven-person crew are never far from the hearts and minds of those



rededicated to making human space flight as safe as possible. NASA's strategies for safely resuming Shuttle flights are detailed in this section covering Space Shuttle Return to Flight safety enhancements. It serves as a guide to how NASA - its government and contractor workforce - has eliminated the potential for debris that could damage the Space Shuttle. It also details how the agency plans to identify, inspect and repair damage in flight, if needed, while improving technical excellence, internal communications and decision-making. And - in the very unlikely event that it's needed - the agency is providing a plan for keeping a Space Shuttle crew safe until a rescue mission could be launched.

NASA is committed to returning the Space Shuttle to flight -- safely -- to fulfill its mission in the Vision for Space Exploration.

IMPROVEMENTS IN TECHNICAL EXCELLENCE, COMMUNICATIONS AND DECISION-MAKING



Two groups play a major role in the decisions associated with NASA's Return to Flight effort: NASA's Space Flight Leadership Council and the independent Return to Flight Task Group.

In parallel with Return to Flight activities after the Columbia accident, a team was formed to review the [Columbia Accident Investigation Board's](#) report and recommendations to determine applicability across the agency. This agency-wide group was led by Al Diaz, Associate Administrator for Science and culminated in its team report: "A Renewed Commitment to Excellence."

Additionally, the agency established the [NASA Engineering and Safety Center](#), which focuses more attention and resources on engineering excellence throughout the agency. Though based at the NASA Langley Research Center, Hampton, Va., this group has membership based at agency field centers that are integrated and involved with engineering reviews, challenges and decisions throughout the agency.

While hardware changes were ongoing, internal management and organizational structures were reviewed and updated as appropriate. The Space Shuttle Program Mission Management Team was one of those scrutinized the most following the Columbia accident and has undergone a complete review and restructure under the leadership of Deputy Shuttle Program Manager Wayne Hale, who will chair its meetings each day throughout a Shuttle flight.

More detail on each of the above organizations is below and available on the Internet at www.nasa.gov and other sites.

SPACE FLIGHT LEADERSHIP COUNCIL

The Space Flight Leadership Council (SFLC) is the group in charge of the agency's Return to Flight efforts. Established before the Space Shuttle Columbia accident, the SFLC is regularly briefed on the overall activities and progress associated with Return to Flight. When the Space Shuttle Program defines a course of action addressing a CAIB recommendation or other major program issues, the next step is to brief the SFLC during periodic meetings. The SFLC is fully briefed and approves, if necessary, the actions to be taken. Additionally, the SFLC assess overall cost, schedule and policy issues.

The members are:

- **Walter H. Cantrell** (co-chair) – Dep. Chief Engineer for Independent Technical Authority
- **William Readdy** (co-chair) – Associate Administrator for Space Operations
- **Bryan O'Connor** – Associate Administrator for Safety and Mission Assurance
- **James Kennedy** – Kennedy Space Center Director
- **Jefferson D. Howell** – Johnson Space Center Director
- **David King** – Marshall Space Flight Center Director
- **Thomas Donaldson** – Stennis Space Center Director
- **Michael Kostelnik** – Dep. Associate Administrator for International Space Station and Space Shuttle Programs

RETURN TO FLIGHT TASK GROUP (STAFFORD-COVEY)

During the investigation following the Columbia accident, the NASA Administrator determined it was in the public interest to establish the [Return to Flight Task Group](#). Co-chaired by former astronauts Tom Stafford and Richard Covey, the group is conducting an independent assessment of NASA's actions to implement the recommendations of the Columbia Accident Investigation Board (CAIB), as they relate to the safety and operational readiness of STS-114. As necessary to their activities, the Task Group consults with former members of the CAIB.

While the Task Group was not chartered to assess the adequacy of the CAIB recommendations, it does report on the progress of NASA's response to meeting the intent of the recommendations and offers observations on safety or operational readiness, as appropriate.

The Task Group draws on the expertise of its members and other sources to provide its assessment to the Administrator and has held meetings and made site visits, as necessary, to accomplish its fact-finding.

Functioning solely as an advisory body, the Task Group established three panels in areas related to its work. The panels report their findings and recommendations to the full Task Group during periodic plenary sessions.

In order to reflect a balance of views, the Task Group consists of non-NASA employees and one NASA non-voting, ex officio member: the Deputy Associate Administrator for Safety and Mission Assurance. Members of the Task Group and panels were chosen from among industry, academia, and government with recognized knowledge and expertise in fields relevant to safety and space flight.



Return to Flight Task Group

SPACE SHUTTLE PROGRAM MISSION MANAGEMENT TEAM

During Space Shuttle missions, the Shuttle Mission Management Team is responsible for oversight of the operations teams during pre-launch and in-flight. The countdown and flight operations are conducted by the operations teams according to rules and procedures approved by SSP Management well prior to real-time events.

While the Mission Operations team leads all nominal flight operations, the MMT provides

guidance to the operations teams for situations that fall outside normal operations, and also redefines programmatic priority when in-flight issues or off-nominal conditions result in conflicting priorities.

Up to and including Columbia's STS-107 mission, actions were biased toward the immediate decision-making required of in-flight operations, which did not adequately address the concerns of individual engineers, the quality of risk assessments, and pedigree of engineering assessments.



The MMT conducts training from the Mission Control Center in preparation for Discovery's Return to Flight.

Now, the Mission Management Team is fully engaged and trained to focus on clearer communication processes centered on bringing out differing opinions; maintaining awareness of decisions that impact the remainder of the flight; and ensuring an understanding of the roles and responsibilities of team members and supporting working groups and teams, including data sharing processes and required milestones to support real-time operations.

To ensure that all issues are identified, cataloged and resolved more effectively, a process has been established whereby the Program's Systems Engineering and Integration Office will maintain an integrated anomaly list, which will be briefed and reviewed at each day's MMT meeting. Each issue (or anomaly) will be assigned to a specific office or organization for technical evaluation and will be subject to an independent risk assessment by Safety & Mission Assurance.

The MMT includes one Shuttle Program S&MA core member, and three institutional S&MA advisory members from the Johnson Space Center, Kennedy Space Center and Marshall Space Flight Center. Additionally, the MMT has added the Space Shuttle System Technical Warrant Holder as a core voting member representing the NASA Independent Technical Authority.

Additional improvements were made to MMT internal processes and procedures, including more clearly defining requirements for MMT meeting frequency and the process for requesting an emergency MMT meeting. NASA now will conduct daily MMT meetings beginning with the launch minus two (L-2) day MMT.

Membership, organization, and chairmanship of the preflight and inflight MMT have been standardized. Space Shuttle Program Deputy Manager Wayne Hale will chair both phases of the MMT – preflight and on-orbit. Membership has been expanded and augmented with each MMT member trained in clearly defined processes for support and problem reporting.

Formal processes have been established for the review of findings from ascent and on-orbit imagery analyses, post-launch hardware inspections, ascent reconstruction, and all other flight data reviews to ensure timely, effective reviews of key data by the MMT.

Procedures for flight MMT meetings have been standardized through the use of predefined templates for agenda formats, presentations, action item assignments, and readiness polls. This ensures that communication and resolution of issues are performed in a consistent, rigorous manner.

As part of an overall agency effort to examine and enhance the safety culture within NASA, Behavioral Science Technology (BST) was hired to assist with understanding and improving culture specifically in the areas of communication, individual consideration, management credibility and decision-making. Locally led implementation teams and former flight directors were invited to observe and assess the MMT process and offer recommendations. This ongoing effort has led to more efficient resolution of critical issues and more open communication among MMT members.

Extensive research on improving communications led to a redesigned MMT meeting room – designated the MMT Command Center – which provides increased seating capacity and communications improvements. Included is a video-teleconferencing capability, a multi-user collaboration tool, and a larger room allowing space for more subject experts and MMT members.

A large “C” shaped table now seats all members of the MMT and invites open communication by eliminating a hierarchical seating arrangement. The MMT Command Center has been operational since November 2004.

To ensure adequate back ups, at least two people have been trained to fill each MMT core position for Return to Flight. This protects the integrity of the integrated MMT process against any core individuals’ inability to perform his or her role for any reason. Verification of each flight-specific team will be presented at the appropriate Flight Readiness Review traditionally held approximately two weeks prior to launch.

The evolution of the MMT is from what previously was an operationally-oriented, problem-solving team to a critical decision-making management body. Technical engineering sub-teams perform the engineering root-cause analysis, technical problem-solving, and identify options and make recommendations to the MMT. This has resulted in more focused decision-making by the MMT and better utilization of the expertise of the MMT membership.

Any action items defined during missions now contain clear delineation of the responsibility of each, which has eliminated some of the pre-Columbia duplication and confusion over roles and responsibilities, particularly in the area of in-flight anomalies.

Risk management is now a major consideration at each MMT meeting. Each identified hazard is required to have a risk assessment performed and presented, so the appropriate risk versus risk tradeoffs can be discussed and dispositioned.

THE MISSION MANAGEMENT TEAM:

POLLED ONLY ON LAUNCH DAY	1. Lockheed Martin Michoud Space Systems
	2. External Tank
	3. Thiokol Propulsion
	4. Redesigned Solid Rocket Motor
	5. Solid Rocket Booster
	6. Rocketdyne
	7. Space Shuttle Main Engine
8. Marshall Space Flight Center (MSFC) Engineering	
9. Deputy Program Manager – MSFC	
10. Hamilton Sundstrand	
11. Extravehicular Activity (spacewalks)	
12. United Space Alliance (Shuttle prime contractor)	
13. Johnson Space Center (JSC) Engineering	
14. Orbiter	
15. Flight Manager (STS-114)	
16. Mission Operations Directorate	
17. Space & Life Sciences	
18. Flight Crew Operations	
19. International Space Station Program Manager	
20. Department of Defense Mission Support (DDMS)	
21. Launch Integration Manager	
22. Shuttle Processing (Kennedy Space Center)	
23. Deputy Program Manager (KSC)	
24. Systems Engineering and Integration	
25. Flight Operations and Integration	
26. Space Shuttle Program Safety & Mission Assurance	
27. Space Shuttle Technical Warrant Holder	
· MSFC S&MA	
· KSC S&MA	
· JSC S&MA	
· NASA Engineering and Safety Center	

NASA ENGINEERING AND SAFETY CENTER

The [NASA Engineering and Safety Center](#) is an independent organization chartered in the wake of the Columbia accident to serve as an agency-wide technical resource focused on engineering excellence. The objective of the NESC is to improve safety by performing in-depth independent engineering assessments, testing, and analysis to uncover technical vulnerabilities and to determine appropriate preventative and corrective actions for problems, trends or issues within NASA's programs, projects and institutions. The NESC draws upon engineering expertise within NASA and includes partnerships with other government agencies, national laboratories, universities and industry.

The objective of the NESC is to improve safety by performing various independent technical assessments of issues within NASA programs. A multi-disciplined team of experts, assembled specifically to address the issue at hand, conducts each of these technical assessments. This approach has been modeled after the "tiger team" concept often used by programs to solve challenging problems. Other services and activities of the NESC are:

Technical Inspections – Used to evaluate the technical adequacy of a particular area within a program, even if a problem has not yet been detected. Examples of potential inspection areas include: math models, analytical tools, manufacturing procedures, test procedures, vehicle processing, troubleshooting techniques, manufacturing tooling, ground support equipment, or special test equipment.

Technical Consultation – An independent evaluation of a specific technical item by representatives of the NESC. This is provided when the scope of a problem or concern does not warrant a full assessment. In addition, a technical consultation also can be provided when an NESC member joins an existing review team or monitors an existing operation or process.

Technical Support – The NESC provides support by making its network of experts and resources available to programs, projects and NASA centers. Technical support is funded by the requesting organization and would not be considered an NESC endorsed activity. The NESC remains independent of the activity, and any individuals called upon by the requesting program or NASA center does not perform an independent technical assessment on the same issue.

Technical Advocacy – This role provides technical expertise, testing or analysis in support of Safety & Mission Assurance organizations, institutional engineering, and programs and projects as necessary. The NESC promotes positive actions taken by individuals, programs or projects to correct identified technical inadequacies.

Dissenting Opinions – The NESC cultivates an environment that encourages and seeks out dissenting opinions. In order to encourage this open environment, and soliciting alternative perspectives, the NESC established a process for addressing dissenting opinions. As a matter of practice, each independent technical review, assessment and analysis seeks dissenting opinions for review and evaluation. These



dissenting opinions are documented and dispositioned in each report and/or briefing.

RENEWED COMMITMENT TO EXCELLENCE

An agency-wide team, under the leadership of Al Diaz, Associate Administrator for Science, was commissioned to assess the broader implications of the Columbia Accident Investigation Board's Report on activities agencywide. The final Diaz Team Report, "A Renewed Commitment to Excellence" was released on January 30, 2004.

The team concluded that 85 of the 193 recommendations, observations and findings of the CAIB Report were applicable across the entire spectrum of NASA's activities. The implementation plan for the Diaz Team Report can be found on the Internet at:

http://www.nasa.gov/pdf/58676main_Implementation_033004_FINAL.pdf

SPACE SHUTTLE PROCESSING IMPROVEMENTS



REINFORCED CARBON-CARBON WING PANELS AND NOSE CAP

During re-entry into Earth's atmosphere and traveling more than 17,000 miles per hour, the Space Shuttle's exterior temperatures can reach up to 3,000 degrees Fahrenheit (1,600 Celsius).

To protect the Orbiters, all external surfaces are covered with various types of Thermal Protection System (TPS) materials. The main types of thermal materials are Reinforced Carbon-Carbon (RCC), low- and high-temperature reusable surface insulation tiles, felt reusable surface insulation blankets and fibrous insulation blankets.

RCC is used on the wing leading edges, the nose cap and an area just behind the nose cap on the lower surface (chin panel), and the area immediately around the forward Orbiter/External Tank structural attachment points. Each wing leading edge consists of 22 RCC panels, numbered from 1 to 22 moving outboard on each wing. Because of the shape of the wing, each panel is unique in size and shape.

The basic RCC composite is a laminate of graphite-filled rayon fabric, further filled with phenolic resin and layered - one ply at a time - in a unique mold for each part, then cured, rough-trimmed, drilled and inspected. To prevent oxidation, the outer layers of the carbon substrate are covered in a .02 to .04-inch-thick layer of silicon carbide in a chamber filled with argon at temperatures up to 3,000 degrees Fahrenheit.

Previous flight history showed that RCC components have been struck by objects, but

never resulted in a complete penetration. Post-flight RCC component inspections for cracks, chips, scratches, pinholes and abnormal discoloration were primarily visual, with tactile evaluations (pushing with a finger) of some regions. Minor repairs to the silicon carbide coating and surface defects were completed at Kennedy Space Center, Florida.

At the time of the STS-107 mission, most of the panels on Columbia's left wing were original parts (built in the 1970s). Only panel 10-left, T-seal 10-left, panel 11-left and T-seal 11-left had been replaced (along with panel 12 on the right wing). Minor surface repairs had been made to several panels and T-seals on both wing leading edges.

After the Columbia accident, the Columbia Accident Investigation Board (CAIB) submitted findings to NASA recommending non-destruction evaluation (NDE) inspection, repair and/or replacement of all wing leading edge panels and associated attachment hardware prior to Return to Flight.

The Kennedy Space Center Space Shuttle processing team began removing and inspecting all wing leading edge panels on the three remaining Shuttles. Beginning in 2003, batches of panels from the wing leading edge and the nose caps, expansion seal and chin panel were removed from the vehicles and sent to Lockheed Vought in Dallas, for NDE inspection.

The traditional NDE methods employed included:

- Through-Transmission Ultrasound (TTU) on all accessible areas.
- Film-based radiology (X-ray) of RCC corners where TTU could not be performed.

- Sampling of the coating using eddy current to determine the silicon carbide coating thickness.

In addition to these traditional NDE methods performed at the vendor for Return to Flight, KSC conducted advanced NDE using Flash Thermography and Through Transmission Thermography on all accessible areas of the RCC panels including the wing leading edge, the nose cap, expansion seal and chin panel of the RCC. This advanced method utilized infrared imaging to characterize internal flaws.

All of these NDE inspections sought to identify internal hidden flaws in the RCC and the outer silicon carbide conversion coating. Any suspect findings would have required additional NDE, including digital radiography and/or computed tomography. Findings then are submitted to an engineering team for evaluation to determine if requirements are met.

It is now a requirement that after Return to Flight and between every mission, flash thermography is performed on the critical areas of wing leading edge, the nose cap, chin panel and expansion seal, in addition to the visual and touch tests. Other advanced NDE methods may be used if warranted.

While some minor repairs were performed at KSC, all necessary repairs and refurbishment to RCC panels was performed by the vendor in Dallas.

Additionally, the nose cap on each vehicle was inspected and only Endeavour's had silicone carbide coating damage that required its removal and replacement with a spare.

WING LEADING EDGE STRUCTURAL SUBSYSTEM

The Space Shuttle processing team performed modifications to the lower two inches of the

front spar to prevent any flow or heat from getting inside and behind the wing edges during launch and landing. The spar is the primary load-carrying structure in the wing to which each of the 22 panels is attached.

Flow restrictors, comprised of a pair of 3/8-inch-diameter knitted Inconel wire springs wrapped in a Nextel fabric sleeve and stuffed with Saffil batting, were added across the four-inch box beam located in the lower RCC access panels 5 through 13. This reduces the effects of temperature on the spar in the event of a breach in the panel or adjacent T-seal.

Also for this reason, a thick strain isolator pad was bonded to the lower spar cap and to the forward-facing corrugations of the spar. Also, the "horse collar" gap filler was redesigned to add a 0.50-in-diameter sleeve at the inner mold line end to increase additional sealing capability in the event of partial tile loss.

RUDDER SPEED BRAKE

The Rudder Speed Brake (RSB) is part of the Shuttle's tail assembly. Located on the trailing edge of the vertical stabilizer, the RSB provides directional and speed control of an Orbiter. The RSB is driven by four actuators powered by a drive shaft. Like a traditional aircraft, the rudder swings from side to side to steer the Orbiter as it descends through the atmosphere. It also functions as a speed brake to slow the Orbiter down. When braking is needed, the sides of the rudder vertically split into two separate surfaces and flare out to provide air resistance.

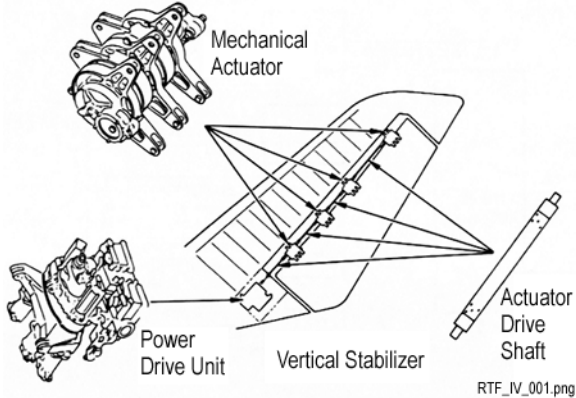

The Rudder Speed Brake consists of two panels, four actuators and a drive shaft

In late 2002, internal corrosion was discovered in the body flap actuators of Atlantis (OV-104). Following the finding, the body flap actuators onboard Discovery (OV-103) were inspected and also found to be corroded and in need of refurbishment. Space Shuttles also use the same type of actuator in their RSB assembly. Because of the component commonality, NASA elected to inspect and refurbish the RSB actuators. The RSB actuators became an issue because corrosion inside the units could result in jamming of the RSB.

During the refurbishment of Discovery's RSB actuators, it was discovered that planetary gears in actuator No. 4 had been installed inverted. Gears in Discovery's other actuators also showed pitting and wear. Furthermore, X-ray analysis of replacement stock actuators revealed actuator No. 2 to have its planetary gear improperly installed, as well.



Actuator inspection using X-ray analysis

Following identification of the corrosion and planetary gear issues, actuators from all three Orbiters were returned for refurbishment to their original manufacturer, Hamilton Sundstrand. Included in the refurbishment service were replacement actuator No. 2 and Discovery's original actuators. During the refurbishment process, Hamilton Sundstrand was in charge of quality control and ensuring proper reassembly of the actuators.

Upon the return of replacement actuator No. 2, the entire set of replacement actuators was installed on Discovery. This was the first time in Space Shuttle Program history that complete installation of the RSB components was performed entirely at Kennedy Space Center.



Actuator installation on Discovery

While the amount of corrosion originally found on the actuators was only minor, a flight limit has been placed on the components. For the initial Return to Flight missions, the actuators will be restricted to five flights. However, the actuator flight limits could be raised to seven missions if post-flight inspections show they are in good condition and working properly.

FOREIGN OBJECT DEBRIS

Beginning in 2001, debris at Kennedy Space Center (KSC) was divided into two categories: "processing debris" and foreign object debris (FOD). FOD was defined as debris found during the final or flight-closeout inspection process. All other debris was labeled processing debris. This led to the perception that processing debris was not a concern.

NASA and United Space Alliance (USA), subsequently have changed work procedures to consider all debris equally important and preventable. Rigorous definitions of FOD that are the industry standard have been adopted (from National Aerospace FOD Prevention, Inc.). These guidelines and industry standards include FOD, Foreign Object Damage, and Clean-As-You-Go. FOD is redefined as "a substance, debris or article alien to a vehicle or system which would potentially cause damage."

KSC chartered a NASA/USA team selected for its experience in FOD-related disciplines including processing, quality, and corrective engineering; process analysis and integration; and operations management. The team began by fact-finding and benchmarking to better understand the industry standards and best practices for FOD prevention. Members visited the Northrup Grumman facility at Lake Charles, La.; Boeing Aerospace at Kelly Air Force Base, Texas; Gulfstream Aerospace in Savannah, Ga.; and the Air Force's Air Logistics Center in Oklahoma City, Okla. At

each site, the team studied the FOD prevention processes, documentation programs, and assurance practices.

Armed with this information, the team developed a more robust FOD prevention program that not only responded to a Columbia Accident Investigation Board (CAIB) recommendation, but also raised the bar by instituting additional improvements. The new FOD program is anchored in three fundamental areas of emphasis:

- Eliminate various categories of FOD, including "processing debris," and treats all FOD as preventable and with equal importance.
- Re-emphasize the responsibility and authority for FOD prevention at the operations level.
- Elevate the importance of comprehensive independent monitoring by both contractors and the Government.



USA also has developed and implemented new work practices and strengthened existing practices. This reduces the chance of temporary worksite items or debris to migrate to an out-of-sight or inaccessible area, and it serves an important psychological purpose in eliminating visible breaches in FOD prevention discipline.



FOD “walkdowns” have been a standard industry and KSC procedure for many years. These are dedicated periods during which all employees execute a prescribed search pattern throughout the work areas, picking up all debris. USA has increased the frequency and participation in walkdowns, and also has increased the number of areas regularly subjected to them. USA also has improved walkdown effectiveness by segmenting walkdown areas into zones. Red zones are all areas within three feet of flight hardware and all areas inside or immediately above or below flight hardware. Yellow zones are all areas within a designated flight hardware operational processing area. Blue zones are desk space and other administrative areas within designated flight hardware operational processing areas.



Additionally, both NASA and USA have increased independent monitoring of the FOD

prevention program. USA Process Assurance Engineers regularly audit work areas for compliance with such work rules as removal of potential FOD items before entering work areas and tethering of those items that can be removed (e.g., glasses), tool control protocol, parts protection, and Clean-As-You-Go housekeeping procedures. NASA Quality personnel periodically participate in FOD walkdowns to assess their effectiveness and oversee contractor accomplishment of all FOD program requirements.

The new FOD program’s effectiveness is measured by a set of metrics to guide improvements. FOD walkdown findings are tracked in the Integrated Quality Support Database. This database also will track FOD found during closeouts, launch countdowns, post-launch pad turnarounds, landing operations, and NASA quality assurance audits. “Stumble-on” FOD findings also will be tracked. For all metrics, the types of FOD and their locations will be recorded and analyzed for trends to identify particular areas for improvement. Monthly reports to management will highlight the top five FOD types, locations, and observed workforce behaviors, along with the prior months’ trends.

CLOSEOUT PHOTOGRAPHY PROCESS

Before areas inside and outside of the Space Shuttle and its External Tank/Solid Rocket Booster stack are sealed for flight, closeout photographs are taken in order to visually document the area at the last moments of access. In part, these photos document differences between actual hardware configuration and engineering drawings. This includes photography of the Orbiter, Space Shuttle Main Engine, Solid Rocket Boosters and External Tank.

Because of the complexity of the Shuttle’s engineering drawing system, the CAIB recommended the photo closeout system be

reviewed and upgraded due to potential for errors.

Portions of these requirements were met by the existing closeout photo process, the KSC Quality Data Center film database and the digital Still Image Management System (SIMS) database. However, prior to the digital photography upgrade, images were difficult to locate and retrieve, because the process required substantial cross-referencing of sources.

NASA formed a Photo Closeout Team from the Agency’s engineering, quality and technical communities to identify and implement necessary upgrades to the processes and equipment involved in vehicle closeout photography. The Photo Closeout Team divided the CAIB recommendation into two main elements:

- Increase the quantity and quality of closeout photographs. The Photo Closeout Team led an extensive review of existing and potential closeout photo requirements. The multi-center, NASA and contractor team established a revised set of requirements, including improved closeout photography of tools for Extravehicular Activity (EVA) contingency configurations and middeck and payload bay configurations. General closeout photography also is being performed at the time of the normal closeout inspection process. The team also reviewed the closeout photo process, which prompted improved formal photography for KSC-generated documentation, mandatory photography of discrepancies, a standard baseline for photo equipment and photo quality standards.

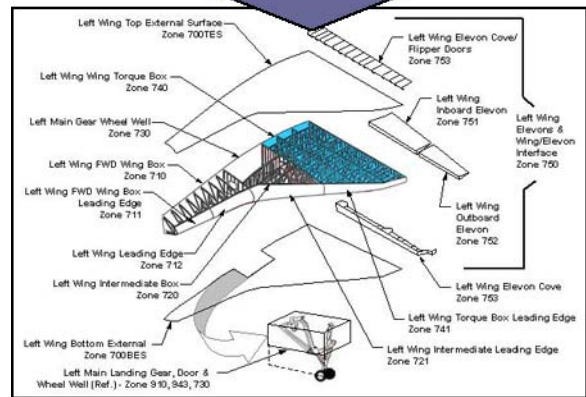
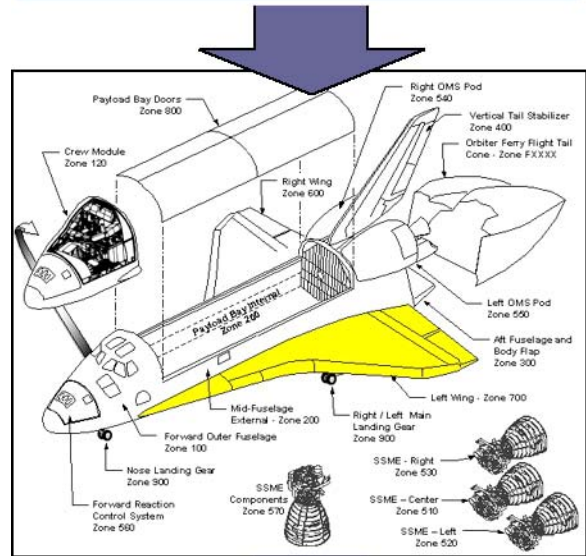
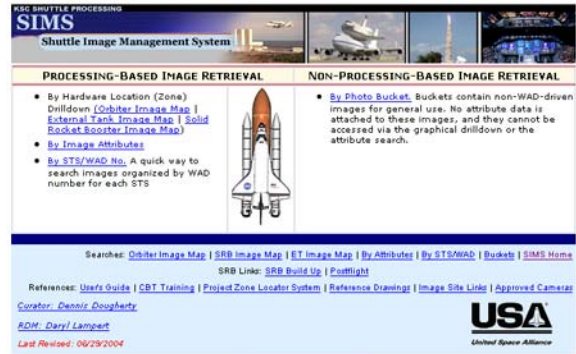

RTF_IV_007.png

Enhanced Still Image Management System (SIMS)

Each of these requirements was incorporated in the photo process. To ensure a comprehensive and accurate database of photos, NASA initiated a training and certification program so that all operators understand and meet the requirements. The ongoing process continually audits photos submitted for archiving.

- Improve the retrieval process through a user-friendly, Internet-based graphical interface system. NASA enhanced the Still Image Management System by developing a web-based graphical interface allowing the engineering community access to Shuttle closeout images. Users now can easily view photos of Orbiter elements and systems. Filters also can be used to limit the search to desired photos. These enhancements enable managers quick and intuitive access to relevant photos, improving their responses to contingencies.

Programs were established to train and certify Quality Control Inspectors, Systems Engineering personnel and end-users at the Johnson Space Center (such as engineers in the Mission Evaluation Room inside Mission Control). The SIMS database also is used as a tool in conjunction with launch simulation scenarios to enhance engineering and mission management training.

LAUNCH PAD GROUND SUPPORT EQUIPMENT

Launch Complex 39, Pads A and B originally were built in the 1960s for the Apollo program. Both were used to launch manned spaceflights during Apollo, Skylab, Apollo-Soyuz and Space Shuttle missions. Each was designed to support the concept of mobile launch operations, which means the launch vehicle is transported to the launch pad by large, tracked crawlers for final processing toward launch.



FIXED AND ROTATING SERVICE STRUCTURES

Key pad service structures were mobile during the Apollo era, but for the Space Shuttle, two permanent service towers were installed at each pad – the Fixed Service Structure (FSS) and the Rotating Service Structure (RSS).

The FSS stands 347 feet from ground level to the tip of its lightning mast and includes three retractable swing arms providing services or access to the Shuttle on the pad.

The RSS rotates around the orbiter and is retracted before launch and provides protected access to the Orbiter for installation and servicing of payloads at the pad.

Launch Pad 39B is designated the Return to Flight launch pad. To correct the critical debris issue that existed on the pad structure, all of the old zinc coating was removed from the two service structures using abrasive blasting with a coal slag grit called “black beauty.” The structures were re-coated with a layer of zinc paint and an inorganic topcoat. The coating systems on the wing covers of the RSS was changed from the inorganic topcoat to a layer of epoxy, and a coating of polyurethane sealant, which significantly reduces the porosity and prevents future oxidation and debris.

During modifications in 2003, Launch Pad 39A received an upgraded electrical power system and new safety tie-off points. In 1992, all metal structures were abrasive blasted to remove oxidation and repainted as part of corrosion control.

UPPER HINGE COLUMN BEARING

Further reviews of the launch pad system indicated the load on the upper hinge column bearing at the top of the hinge between the Fixed Service Structure and Rotating Service Structure was 20 percent over the designed weight. The hinge materials were redesigned to increase their strength.

GASEOUS OXYGEN VENT ARM (“BEANIE CAP”)

The Gaseous Oxygen (GOX) Vent Arm, located 265 feet above the launch tower, includes duct tips that were redesigned to provide more efficient delivery of heated gaseous nitrogen. The vent arm extends over the External Tank during prelaunch loading of hydrogen and oxygen to provide a means of preventing ice formation on the ET nose cone. Ice formation presents a debris concern to the tile and wing leading edge panels on the Shuttle. The vent arm has a system of heaters and tubing (ducts) that direct heated gaseous nitrogen to the ET nose cone vents to warm the gaseous oxygen and then carry it away from the Shuttle. The new tips as well as a large section of ducting has been built and installed to preclude any ice debris concern at the top of the External Tank.

GASEOUS HYDROGEN VENT ARM

The Gaseous Hydrogen Vent Umbilical provides a means of safely transporting hazardous gaseous hydrogen, vented during cryogenic loading from six hours through launch, away from the External Tank to the facility vent system. The vent line and umbilical system is located 215 feet up the launch tower and attaches to the tank’s

intertank flight umbilical carrier plate, which provides a vent for the liquid Hydrogen tank portion of the External Tank. It also provides a connect point for the tank’s pneumatic and electrical systems.

At liftoff on a previous Shuttle mission (STS-108) the Vent Line/Carrier Plate Assembly contacted the launch tower structure upon retraction into the tower latching mechanism. Several pieces of the assembly broke off, which led to a concern that debris could possibly contact the Shuttle as it lifts off the pad.

A review of the problem revealed that allowable wind conditions for a Shuttle launch could provide enough push to drive the vent line into the launch tower if the wind was from a certain direction and velocity. To prevent it from occurring again under any conditions for a Shuttle launch, the launch tower structure was modified by enlarging the opening that the vent line enters by about nine inches to allow the Vent Line/Carrier Plate Assembly to safely enter the tower structure and engage the latching mechanism under all launch conditions.

CRAWLER TRANSPORTER

Before Return to Flight, NASA’s two Crawler Transporter vehicles underwent replacement of the 456 tread belt “shoes” on each vehicle. Each of the vehicles has eight belts, and each belt has 57 shoes. Each shoe is 7½ feet long and 1½ feet wide and weighs approximately 2,100 pounds.

Most shoes on the transporters dated back to 1965, when they were built and first put into service for Apollo launches.

KSC system engineers and technicians worked on the sprockets and rollers on each belt before the new shoes were installed. Welding repair and inspection of some of the sprockets and manufacture of some of the rollers were performed in the Launch Equipment Support Facility.

Other upgrades or modifications recently completed on the transporters included completing electrical rewiring of the motor control center and installation of new driver cabs, mufflers, radiators and ventilation systems.



Crawler Transporter vehicle

PREPARING THE EXTERNAL TANK



About six hours before Space Shuttle Discovery's launch, its bright orange 15-story-tall fuel tank is loaded with 535,000 gallons of liquid hydrogen and oxygen.

Just before liftoff, these super cold liquids mix to generate fuel for the Shuttle's three main engines, which gulp it at a rate equal to emptying the average size backyard swimming pool in 20 seconds.

Discovery's tank, designated ET-120, has been redesigned over the course of the last 24 months through testing and implementation of improvements that eliminate the chance of

Shuttle-damaging foam coming off during launch and the climb to orbit. It is undoubtedly the safest, most reliable tank ever built.

The External Tank's aluminum skin is a tenth of an inch thick in most places and is covered with polyurethane-like foam averaging an inch thick, which insulates the propellants, prevents ice formation on its exterior, and protects its skin from aerodynamic heat during flight. About 90 percent of the foam is applied via automated systems, while the remainder is sprayed on manually.



LO₂ Feedline bellows ice

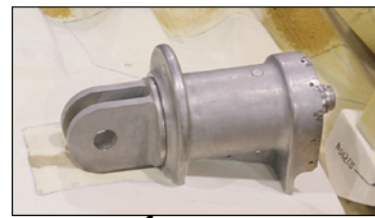

Bipod



LO₂ PAL ramp

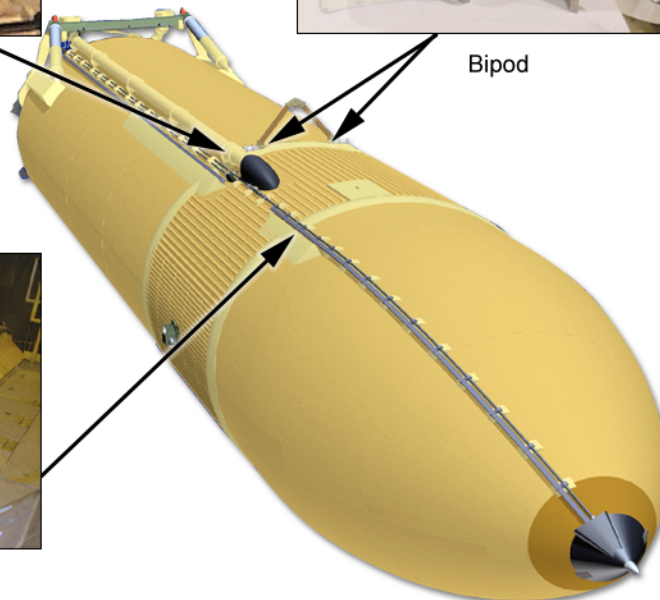

RTF_V_001.png

External tank areas of emphasis

A specially formed piece of foam protecting the Shuttle's forward attach point was determined to have fallen off during Columbia's launch on Jan. 16, 2003, which struck the left wing. This allowed the penetration of superheated air into the wing's interior, weakening the structure. This damage eventually caused the loss of aerodynamic control 16 minutes before landing on Feb. 1, 2003.

Even before the formal report of the [Columbia Accident Investigation Board](#) was released, NASA began modifications to reduce the risk from falling debris during ascent. Several safety improvements and foam application process changes are now followed to ensure nothing larger than .03 pound comes off the tank.

These changes and improvements include removal of the foam around the bipod fitting of the forward attach point; installing a small video camera on the liquid oxygen feedline to document launch; reversing bolts on the flange of the tank's mid-section along with a new spraying procedure for that area; redesigning three bellows on the 70-foot liquid oxygen feedline to the main engines; and implementing a more defined foam spraying procedure on the structural support for the tank's aft orbiter attachment struts.

NASA's Marshall Space Flight Center in Huntsville, Ala., is home to the Space Shuttle Propulsion Office, which manages the tank project overseen by prime contractor Lockheed Martin Space Systems Co., in New Orleans at the Michoud Assembly Facility.

BIPOD REDESIGN

The External Tank's forward Shuttle attach fitting - called the bipod - was redesigned to eliminate the large insulating foam ramps as a debris source and replace them with electric heaters.

The ramps were in place to prevent ice buildup - another potential debris source - on the two bipod fittings, which connect the tank to the Orbiter through the Shuttle's forward attach strut.



Development of this redesign concept actually began after some insulating foam from the left bipod ramp area came off during the October 2002 launch of Space Shuttle Atlantis on the STS-112 mission. During launch of Columbia on its STS-107 mission in January 2003, a similar loss prompted NASA's Office of Space Operations (then Office of Space Flight) to mandate a redesign of the bipod ramp.

The foam ramps were wedge-shaped blocks hand sprayed and hand carved to the desired dimensions of about 30 inches by 14 inches by 12 inches to fit over the bipod fittings during the tank's final stages of preparation.



After the Columbia accident, engineering analysis and dissection of existing bipod ramps indicated that hand-spraying over the complex

geometry of the fittings was prone to producing voids and defects that contribute to foam loss during ascent.

The bipod redesign eliminates the foam block allowing the fitting to be mounted atop a new copper plate threaded with four rod heaters placed below each fitting. This prevents ice formation when the tank is loaded with extremely cold cryogenic liquid hydrogen fuel. The copper plate with heaters is sandwiched between the fitting and an existing thermal isolating pad, which reduces heat loss from the copper plate into the extremely cold liquid hydrogen tank.

The heaters are cartridge-type heaters .25 inches in diameter and 5 inches in length with a wire coil inserted into a tube filled with magnesium oxide. Each heater will operate until launch and can produce up to 300 watts of power at 120 volts AC. They will be powered and monitored through connections in the Ground Umbilical Carrier Plate, which separates when the Shuttle is launched.

Control of the heaters will be through ground-based Programmable Logic Controllers that will vary the heater power based on temperature sensors co-located with the heaters at the copper plates. Additional temperature sensors on the bipod fittings will monitor the fitting temperatures to ensure they stay above freezing. To minimize the potential for a launch scrub, the heaters and temperature sensors have built-in redundancy to permit operation even in the presence of certain hardware failures.

Although the original bipod fittings were covered with foam ramps, the bipod spindles, which connected the fittings to the struts, remained exposed. These spindles rotate to account for tank shrinkage that occurs when it becomes extremely cold. These spindles each contained a heater element, which no longer is required. Elimination of the heaters allowed for

smaller end covers made from titanium on the fitting. These already are capable of withstanding higher temperatures caused from aerodynamic heating.



Bipod installation

The new bipod design also requires additional cabling to operate the heating system. It includes four circuits on each bipod (totaling eight) that run from the External Tank Ground Umbilical Carrier Plate to the heaters under the bipod fitting.

This new design is an alternative derived from three original redesign options proposed by the project office to the Space Shuttle Program in May 2003.

A variety of verification tests have been performed to ensure the redesign will meet the requirements for safe flight. Structural tests at Michoud verified the redesign's capability to withstand maximum loading. Two thermal tests at Eglin Air Force Base, Fla., verified the heater system's ability to prevent ice formation. Ten wind tunnel tests at Arnold Air Force Base's Engineering Development Center, Tenn., demonstrated the new design's capability to withstand maximum aerodynamic loads without generating debris.

The Thermal Protection System team developed a two-step closeout process to improve the manual spray technique. Verification and validation of this new process was accomplished on a combination of high-fidelity

mockups and on an existing External Tank test article in a real production environment.

The bipod redesign is being retrofitted on the eight existing tanks and implemented on all new tanks. This work is being done by Lockheed Martin Space Systems at Michoud. Delivery of the first retrofitted tank to the KSC was on Jan. 5, 2005.

LIQUID HYDROGEN (LH2) INTERTANK FLANGE

While the External Tank Project Office worked through the redesign of the bipod fitting and the elimination of its foam ramp, a top-to-bottom assessment was conducted in parallel to examine all areas where the tank's foam insulation could potentially come free during flight.

A result of this process led to new requirements for the joint connecting the liquid hydrogen and liquid oxygen tanks. The area between the two is known as the intertank and basically is the structural connection. Flanges are the joint that functions much like a tab, or seam on a shirt, which are affixed at the top and bottom of the intertank. After the flange is bolted to the LH2 and LO2 tanks, the area is insulated with foam.

Testing and analysis revealed that gaseous nitrogen used to purge the intertank area could potentially turn to liquid when exposed to the extreme cold of the liquid hydrogen, which is minus 423 degrees. Once liquid nitrogen is formed inside the intertank area it can seep into any voids, or spaces, in the foam adjacent to the flange near the liquid hydrogen tank. During launch as pressure builds and heating occurs, the liquid nitrogen rapidly returns to a gaseous state and leaks past the flange bolt threads and nuts on the hydrogen side. This phenomenon is known as cryogenic ingestion and permits small foam pieces, or divots, to fall off the tank.

To prevent this, the flange bolts have been reversed and Loctite applied to the threads, which restricts liquid Nitrogen leakage.

Additionally, a new mold injection foam closeout process of the intertank stringers was instituted to provide technicians with a less complex base, which reduces possible spray defects.

Another phenomenon - cryogenic pumping - is caused when surface air is pulled into foam voids as the tank is being fueled. Again, external pressure changes during launch cause the air to expand and push foam divots off the tank.

With these in mind, an enhanced closeout, or finishing, procedure was instituted, which includes improved foam application to the intertank ribbing area as well as to the upper and lower area of the flange. The improved process allows technicians to apply a higher quality product through process verification and more stringent controls. These controls include engineering evaluation of processing parameters; real-time and video surveillance of the process; and dissection/evaluation of "flight like" witness panels.

New requirements established by the Space Shuttle Program allow debris from this area to be no more than .03 pound of mass.

LIQUID OXYGEN (LO2) FEEDLINE BELLOWS

The next area on the External Tank judged as a potential debris source during the Space Shuttle's climb to orbit was a portion of the liquid oxygen feedline, which includes joints known as bellows.

There are five bellows along the 17 inch-diameter feedline assembly, which extends externally 70 feet along the right side of the Liquid Hydrogen tank up and into the intertank, and down to the bottom of the liquid oxygen tank.

Three of the five bellows are external and in place to allow flexing of the line when being installed. They are adjacent to the Hydrogen

tank and are high enough to present a risk from potential ice that may form during prelaunch tanking. The other two feedline bellows allow the lines to adjust when the liquid hydrogen tank is filled and permit the feedline to adapt to the forces generated at liftoff. These are inside the intertank region and are not a safety of flight issue.

In searching for any area of potential debris, the Space Shuttle Program determined that the original design of the three external bellows could permit formation of ice that ultimately could be shaken free during launch and potentially damage the orbiter. Though this ice liberation typically occurs at relatively low speeds during the initial stages of liftoff and the climb to orbit due to vibration, the potential still exists for ice to come off later when acceleration dictates it would be a more hazardous debris source.

This prompted a redesign to insulate the exposed metal bellows with a Thermal Protection System consisting of aerogel filler and a loosely woven fiberglass cloth bond coated with waterproofing to promote condensate run off. The foam skirt around the bellows rain shield also was extended to divert condensate. This modification is called the “drip lip,” which reshaped the edge in a more squared off approach.

The previous configuration of the feedline bellows was susceptible to significant ice formation when moisture in the air contacted the cold surface of the uninsulated bellows. Though there never were reported losses of foam insulation from this area of the tank, photographs taken before launch indicated ice formation.

The new modifications significantly reduce the potential for dense ice buildup on the bellows, which improves the overall safety of the tank.

PROTUBERANCE AIR LOAD (PAL) RAMPS

The top-to-bottom assessment of the External Tank’s Thermal Protection System led to re-evaluation of other areas in which foam insulation is prone to loss. One of those was the existing design of the Protuberance Air Load (PAL) ramps designed to prevent unsteady air flow underneath the tank’s cable trays and pressurization lines.

Two PAL ramps exist on each External Tank. One is near the top of the liquid oxygen tank, close to the nose cone, while the other is below the intertank, near the top of the liquid hydrogen tank. They consist of thick, manually sprayed layers of foam, which could provide a source of debris. The forward 10 feet of the LH2 PAL ramp was removed and replaced to allow access to the LH2 intertank flange area to implement foam closeout improvements.

An extensive evaluation that included careful dissections to collect data on existing PAL ramps determined location, size and frequency of any voids which are known to promote foam separation due to expansion of trapped air or gases during ascent.

Over the course of six months, seven enhancement sprays were performed on high-fidelity mockups to develop a new spray process, which proved through non-destructive evaluation that not only were fewer voids formed, but those that did form fell into the acceptable range for flight safety.

After comparing all of the data gathered and analyses performed, it was decided that the first two tanks PAL ramps are safe to fly using the current application process with detailed scrutiny of evaluation applied.

An enhanced spray process is in work for future tanks, as well as continued work in developing redesign options including elimination of the ramps; reducing the ramps’

sizes by two thirds; or building a trailing edge “fence” on the back side of the cable tray, which would act like a nozzle throat and prevent unsteady flow in that area.

ENHANCED IN-FLIGHT IMAGERY

A tiny camera mounted on the External Tank’s liquid oxygen feedline fairing will provide real-time views of the orbiter’s underside and wing leading edges as well as portions of the tank.

Several locations were evaluated to provide the best possible video documentation, while ensuring that the camera itself would not become a debris source.

An identical camera flew once before on a tank during Atlantis’ October 2002 mission. That camera was located in a different location near the top of the liquid oxygen tank and provided only a partial view of the orbiter and tank. That location was chosen for the dramatic launch and ascent views offered during the first two minutes of flight until obstructed by the plume effect from the Solid Rocket Booster separation motor.

The new location maximizes the field of view and minimizes the chance of the plume associated with the SRB separation.

NON-DESTRUCTIVE EVALUATION (NDE)

One of the leading methods for evaluating the performance of redesigns, modifications and upgrades to the Space Shuttle systems – particularly the External Tank – is known as non-destructive evaluation (NDE).

Detecting defects nondestructively in manually applied foam presents a unique challenge. Not only is the foam low in density, which makes it difficult to differentiate defects such as voids from the surrounding porous material, but the foam also is irregular making it difficult to differentiate defects from natural variations in the foam.

A team investigated a dozen non-destructive inspection methods from industry and academia before selecting terahertz imaging and backscatter radiography.

Confidence in these new approaches was initially established by testing a wide variety of samples with different defect types and sizes. Terahertz imaging and backscatter radiology were used on the Protuberance Air Load (PAL) ramps on the first two flight tanks (ET-120 and ET-121). These results provided added confidence in the foam application quality.

Further refinement of the terahertz and backscatter technologies capabilities to detect thin voids and defects in more complex foam areas continues, but is a promising tool for reviewing the foam application process without damaging the foam itself.

THERMAL PROTECTION SYSTEM CERTIFICATION

With non-destructive evaluation (NDE) as one method for determining the quality of foam application on the External Tank, assessments of the test verification process were conducted for any critical failure possibility.

The team developed a comprehensive plan to review and document Thermal Protection System (TPS) verification data used to certify the tank's structural integrity as well as debris generation potential. The plan called for a detailed review of each failure possibility, critical flight environments and all other applicable test data.

This approach identified possible deficiencies or areas requiring additional data. One of these, for example, focused on understanding internal defects of foam and their potential to generate debris. To address this issue, additional dissection data was gathered to characterize the internal structure of the foam. A flight tank converted into a test article that never would fly a mission provided the perfect source for most of these dissections. Next, a test program was initiated to develop data on what type and size of internal defect would be acceptable under new debris requirements.

This new plan led to several key decisions, including approval of the redesigned bipod TPS and the fly "as is" determination for first flight tank's PAL ramps.

THERMAL PROTECTION SYSTEM (TPS) VERIFICATION & VALIDATION

One of the more complex approaches to certifying the changes and improvements to the External Tank before flight is to identify the scope of TPS process verification and validation efforts.

This process control dictated the establishment of prerequisites for TPS manual sprays and identified process verification and validation requirements with careful monitoring of their incorporation into the Return to Flight effort.

An integrated process control for the various foam processes was instituted as well as a plan for all tanks in production. After establishing manual spray requirements, tests and dissections were identified that would confirm the process used to certify the foam for flight. Tank dissections, defect testing and margin assessments followed.

The early work, obviously, concentrated on mandatory improvements to the first two flight tanks (ET-120 and ET-121). Attention also was paid to items that were desired on these first tanks, while looking toward longer range TPS improvements.

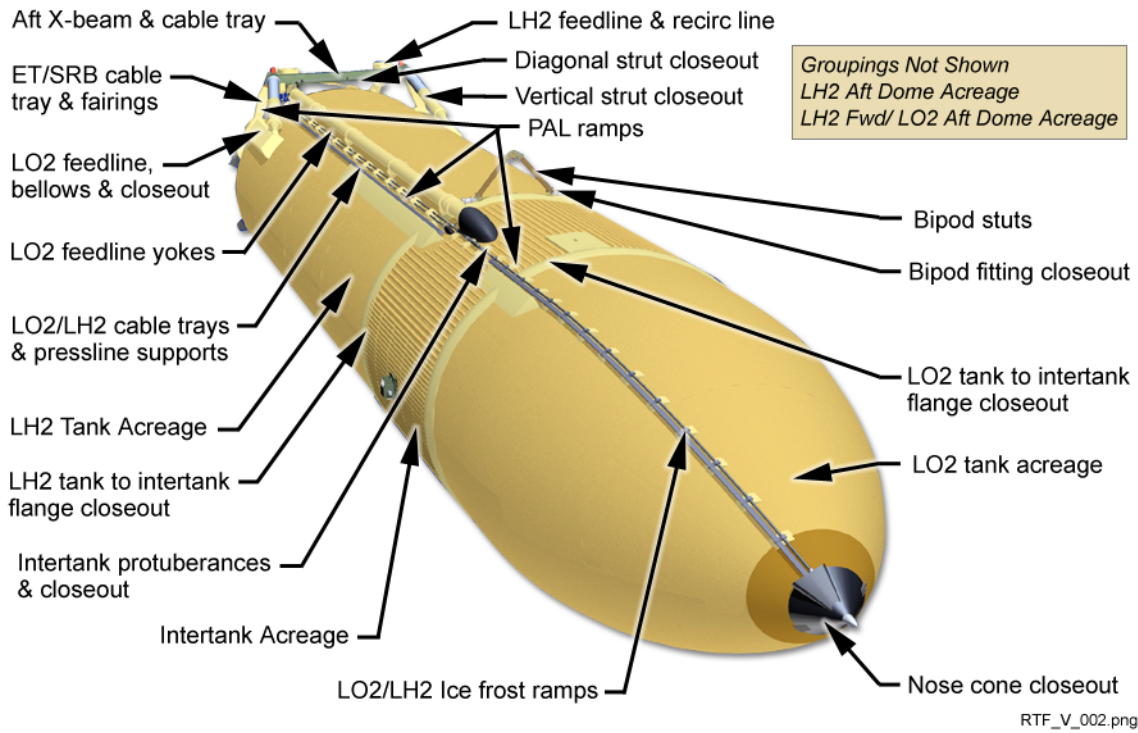

TPS Applications

SOLID ROCKET BOOSTER MODIFICATION

BOLT CATCHER

Part of the Return to Flight effort included identifying every possible area of the Space Shuttle stack (including the Orbiter, External Tank and Solid Rocket Boosters) where potential debris sources existed. One of those identified for redesign was the “bolt catcher” fixed to the forward, or top, of the boosters where they attach to the External Tank. These retainers are designed to capture severed bolts when the boosters separate from the tank approximately two minutes after launch.

Each Shuttle is launched with two bolt catchers, which are located on the boosters. At booster separation, pyrotechnic devices fire to break the bolts that hold them to the tank. The forward bolt is vertically attached to both the Solid Rocket Booster and the External Tank. The canister-like bolt catcher captures the part of the bolt that is retained with the External tank; the other half of the bolt remains with the booster, secured within the forward skirt thrust post.

Though the bolt catcher is mounted on the External Tank, it is considered part of the Solid Rocket Booster element design.

The original bolt catcher design consisted of an aluminum dome welded to a machined aluminum base and bolted to the External Tank’s fittings. It is about 12 inches tall, 8 inches in diameter and weighs about 11 pounds. The inside of the bolt catcher is filled with a metal, honeycomb-like energy absorber to limit the impact of the bolt as it is captured.

The bolt, known as a separation bolt, is about 25 inches long, approximately 3 inches in diameter and weighs about 70 pounds. It has a groove, or separation plane, about 11.5 inches from the top that allows it to break when the pyrotechnic devices fire.

The part of the bolt that remains on the Solid Rocket Booster is inspected after flight to ensure the break was clean. The bolt catcher and the bolt half it captures disintegrate along with the External Tank upon reentry some 45 minutes after launch.

Following the Columbia accident, a series of tests were performed by the Solid Rocket Booster Project Office at NASA’s Marshall Space Flight Center to replicate the loads, or the forces, to which the bolt catcher is subjected during launch. The testing and analysis revealed the bolt catcher had a safety margin that was slightly less than had been previously assessed and required by the Space Shuttle Program, which is 1.4. To achieve the desired safety margin, a redesign effort was undertaken, incorporating a comprehensive testing program.

However, a review of all available still photography and video coverage of the separation on the External Tank revealed that the bolt catchers functioned properly on all flights.

The redesign of the bolt catcher housing now means the unit is made from a single piece of aluminum forging, thus eliminating the weld from the original design. In addition, the wall thickness on the catcher was increased from .125 to .25 inches using a much stronger aluminum alloy (AL7050).

The internal energy-absorbing material also was swapped to one that better absorbs the energy into the bolt catcher when the bolt is released. The original material was a corrugated sheet of aluminum wrapped spirally to attain the cylindrical shape that fit into the bolt catcher. The new design has a more open cell texture, much like a bee’s honeycomb.

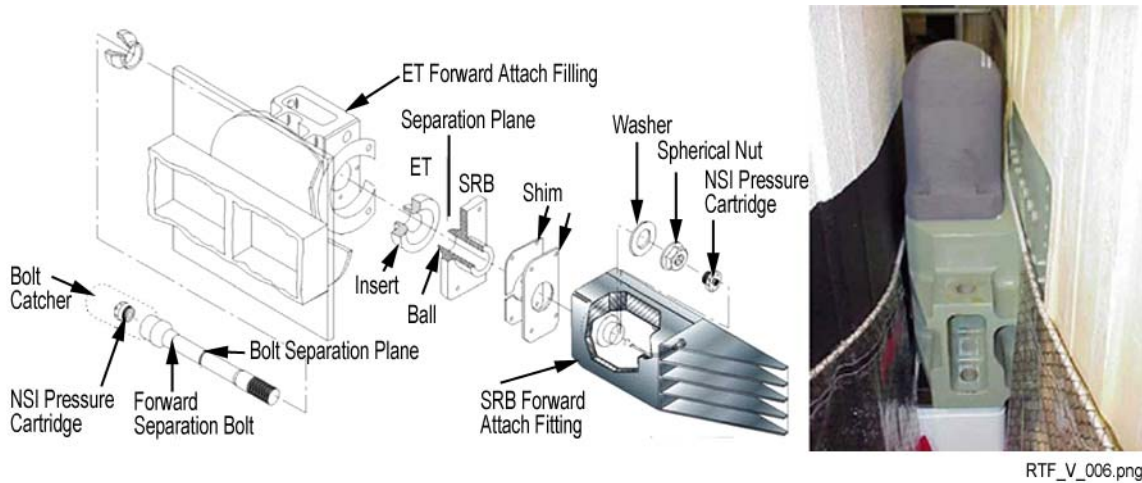

The thermal protection material also is being changed from the original super lightweight ablator to a machined cork covered with a protective paint finish. An ablator or ablative is a material that erodes to dissipate heat, offering a potential for debris during liftoff. Machined cork was selected as its replacement because it has a strong adhesive system that has a proven record of success in other areas on the Solid Rocket Booster. A layer of hypalon paint will protect the cork from moisture.

The External Tank attachment bolts and inserts – those that hold the bolt catcher in place – also were resized from three-eighths inch to nine-sixteenths inch, which adds strength to this area.

A series of static, dynamic and environmental tests of the redesigned bolt catcher then were conducted to determine the design loads and demonstrate the bolt catcher met, or exceeded, the 1.4 factor of safety requirement.

The aft end of the Solid Rocket Booster is attached to the External Tank by three struts, made out of Inconel 718 and designed to react to lateral loads induced during flight. The struts are made in two halves and are held together by aft separation bolts housed inside the struts. When the boosters separate from the

Tank, the bolts are fractured at a predetermined spot by a pyrotechnic device, thus splitting the bolt.

The two halves of the bolt are caught inside the strut halves by honeycomb energy absorbers on each end of the struts. During the past year, the Booster Project tested the strut honeycomb to confirm its capability and its load transfer characteristics. The tests revealed that modifications to the existing hardware were not needed because the current configuration is robust and there are no load or strength concerns.

BOOSTER SEPARATION MOTOR IGNITER

Immediately after the Solid Rocket Boosters separate from the External Tank, igniters called booster separation motors ignite and push the boosters away from the tank and Space Shuttle. These igniters have been redesigned to minimize the risk to the Shuttle.

At booster separation, forward and aft motors ignite to serve as small thrusters to prevent the boosters from contacting the tank or Shuttle. Each of the two Shuttle boosters has eight separation motors, which are small solid fuel rocket motors designed to provide 18,000 pounds of thrust in less than 0.8 seconds. At

separation, a pyrotechnic charge lights the motor igniter, which also consists of solid rocket propellant. The igniter instantly ignites the motors' solid propellant.

The current redesign effort was initiated in 2003, when erratic performance was noted during open-air igniter testing. The test program was designed to qualify new suppliers for igniter propellant ingredients. A government and contractor anomaly resolution team of engineers concluded that the igniter solid propellant was fracturing. The propellant cracks caused erratic performance characteristics, including excessive peak pressures, pressure oscillation, and shortened burn time.

Based on the potential for erratic igniter performance to affect BSM ballistic performance and produce debris, the igniter Return to Flight team, consisting of NASA, United Space Alliance, and Pratt and Whitney engineers, determined that the igniter should be redesigned before the Shuttle returns to flight.

The team established the overall ground rules for RTF: elimination of all propellant damage mechanisms; qualification of the new design for flight and, installation of BSMs with the new igniter design for STS-114 and subsequent vehicles. Testing on the redesigned igniter began in June 2003 beginning with testing of a broad range of design concepts. The test team chose a final design, which has since undergone 53 tests.

Design changes include beveling the solid propellant grain configuration; modifying the retainer design; and, modifying the adapter to direct loads to the center of the retainer plate. These efforts were undertaken with a parallel activity to tighten controls on propellant and material suppliers.

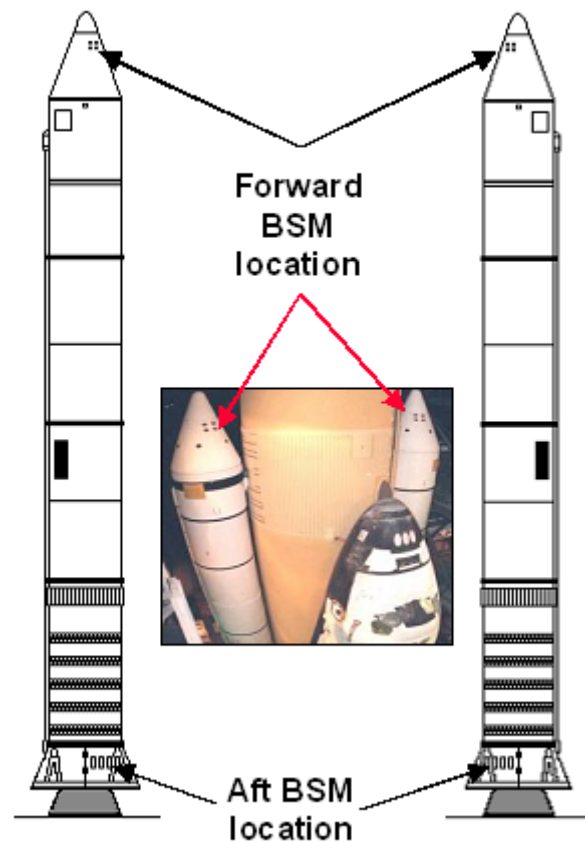

Solid Rocket Booster separation motors ignite two minutes after launch pushing the boosters away from the Shuttle

IMPROVING IMAGERY, DATA COLLECTION FOR SPACE SHUTTLE LAUNCH AND LANDING



Documenting the Space Shuttle’s launch has been enhanced to now include a minimum of three different views from ground sites as well as aircraft-based video from angles never before available. These additional views and cameras will provide much higher fidelity footage for engineers assessing whether any debris came off the External Tank during the first two minutes of flight when the vehicle encounters the highest aerodynamic portions of the ascent. A total of 107 ground and aircraft-based cameras will document Discovery’s launch and climb to orbit.

The Ground Camera Ascent Imagery System was upgraded following the Columbia accident and also will include ship and ground-based radar to compliment the strategically placed cameras. Changes include additional camera sites, upgrades to the cameras themselves, implementation of High Definition Television (HDTV) for quick look analysis, and mirrored server capability to more easily and quickly allow the sharing of imagery between KSC, JSC, and Marshall.

GROUND-BASED IMAGING OF LAUNCH

Before 2003, four short-range tracking cameras were used on the launch pads, at camera site two east of the pad, and at camera site six northwest of the pad.

Remotely controlled from the Launch Control Center adjacent to the Vehicle Assembly Building, one camera focused on the top half of the Shuttle and one focused on the bottom half. Camera site six views the hydrogen vent arm (above the tank) as it swings off the tank and also the underside of the Orbiter’s left wing. Camera site two views the area between the orbiter and

TYPE	NO.	
Infrared (IR)	2	
High Speed Digital Video (HSDV)	2	
70 mm	3	
High Definition (HDTV)	19	
National Television Standards Committee (NTSC)	20	
35 mm	29	
16 mm	32	
TOTAL	107	

LOCATION	TYPE	NO.
Launch Pad 39B (Launch platform & launch tower)	16 mm	30
Launch Pad Perimeter	16 mm	2
	35 mm	5
Short Range Tracking Sites (3)	HDTV	3
	35 mm	6
Medium Range Tracking Sites (6)	70 mm	1
	NTSC	1
	HSDV	2
	35 mm	7
	HDTV	6
Long Range Tracking Sites (11)	70 mm	2
	NTSC	4
	HDTV	5
	35 mm	11
WB-57 Aircraft (2)	Infrared	2
	HDTV	2
Operational Television (OTV)	HDTV	3
	NTSC	9
Public Affairs	NTSC	6
TOTAL		107

the tank to observe any potential debris or ice that might fall.



For Return to Flight, there are three camera sites designated one, two and six. Two new cameras have been added for camera site one, located northeast of the launch pad. The addition of this tracker ensures a view of the underside of the right wing as well as the area between the External Tank and the Orbiter to track any debris during its roll maneuver just after launch. All camera sites have two film and one HDTV video cameras.

The short-range tracking cameras have 200-mm focal length lenses and are loaded with 400 feet of film, running 100 frames per second. In addition to the film cameras around the launch pads, there are 42 fixed cameras with 16-mm motion picture film.

Medium-range trackers are located at six sites: Three along the coast and three near the Launch Complex 39 area. Placement at these sites provides three views for triangulation, to better characterize any suspect area. These cameras have 800-mm and greater lenses, running 100 frames per second. Three of the cameras have 400 feet of film and two have 1,000 feet. The additional tracking cameras have 150-inch lenses, with 1,000 feet of film. Five of six sites also have HDTV video cameras.



Five long-range trackers have existed north and south of the pads, from Shiloh and Playalinda to Cocoa Beach, ranging from 14 miles north to 20 miles south. These additions will reach as far north as Ponce de Leon Inlet, 38 miles from the launch pads, and south to Pigor, 11 miles from the pads. One of the cameras previously located at Patrick Air Force Base has been converted to be transportable and moved to a location north of the pad.

All the cameras have 400-inch focal length and 100 feet per second capability to provide more data points to better track any debris.

Two of the cameras are part of the Distant Object Attitude Measurement System (DOAMS), located at Playalinda Beach and the Cocoa Beach area. A refurbished five-meter focal length telescope recently was installed in the Cocoa

Beach location. Each of these camera sites also will have HDTV video cameras.

A unique feature of the tracking telescopes is a robotic camera manned by a technician sitting on top and gently manipulating a joystick to map the Shuttle's track through the sky.

CAMERAS

A variety of cameras and lenses are used to support ascent imaging, including film and digital cameras.

- 35mm film cameras are used at the pad and on short, medium and long range camera sites and provide the highest resolution dictating they are the primary imagery to meet the minimum size requirements for debris identification during ascent.
- HDTV digital video cameras are co-located with many of the 35mm cameras and provide quick look capability. The digital video data provides the ability to conduct expedited post-launch imagery processing and review (quick look) before the film is processed and distributed.
- National Television Standards Committee (NTSC) – backup for sites without HDTV.
- 70mm motion picture film cameras provide “big sky” views.
- 16mm motion picture film cameras are used on the Mobile Launch Platform and Fixed Service Structure of the launch pad.
- Other cameras are located throughout the launch pad perimeter and other locations providing additional quick look views of the launch.

Cameras are either fixed or mounted on a tracker. A variety of trackers are used at the different camera sites, the predominant tracker being a Kineto Tracking Mount (KTM) tracker. All of the trackers within close proximity to the launch pads are remotely controlled. The remaining

trackers are remotely or manually controlled on-site.



Kineto Tracking Mount tracker

CAMERA LOCATIONS

The ascent ground cameras provide imagery from the launch platform and on the launch tower itself, as well as from short, medium and long-range sites as mentioned above.

Twenty-two 16mm cameras are on the Mobile Launch Platform...

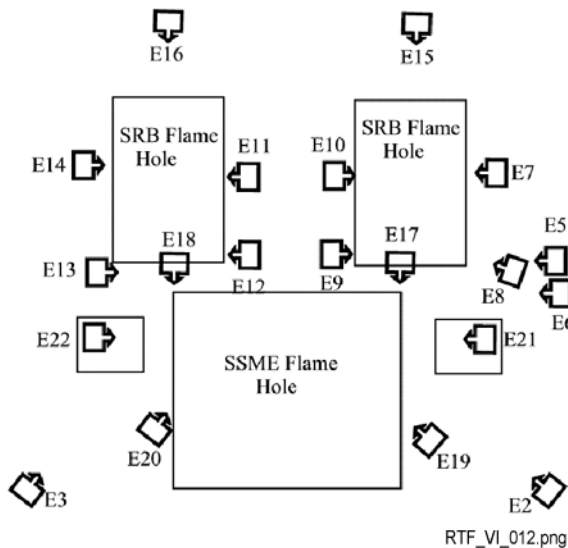

...and eight 16mm cameras are on the launch tower (Fixed Service Structure).

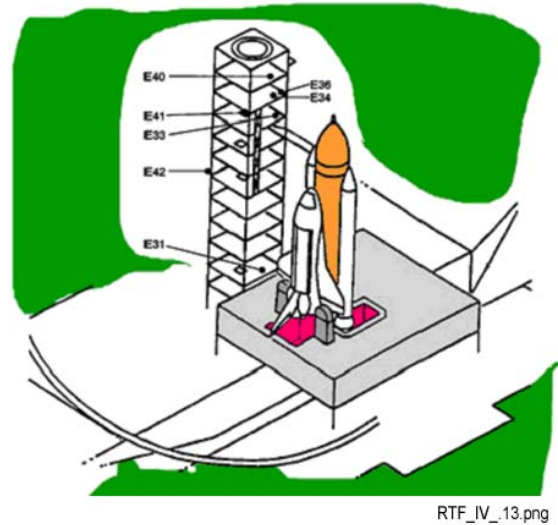

RTF_IV_13.png

The three short-range camera sites are located within the pad perimeter approximately 422 to 432 yards from the launch pads and include two 35mm cameras and an HDTV camera. These sites provide coverage during the early phases of a launch to image individual portions of the Shuttle stack. Once the vehicle clears the launch tower, these cameras can capture larger portions of the Shuttle, but lose the ability to image and track small debris.

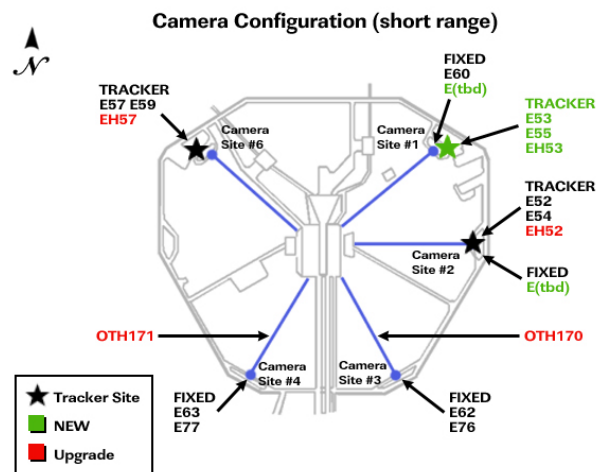

Eleven medium-range sites are located approximately one to six miles away from the launch pads – seven used for Pad 39A and six for Pad 39B. The medium-range sites each have a 35mm camera while 10 of the 11 incorporate

HDTV cameras. Medium-range cameras are used during the early phase of ascent and continue to be used until the distance to the Shuttle becomes too far to identify and track debris.

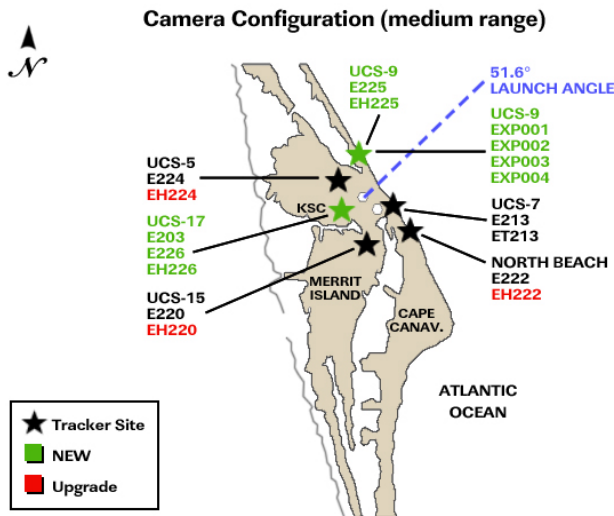

Eleven long-range sites are located approximately four to almost 40 miles away from the launch pads, and support both pads. All of the sites have 35mm cameras, and two have 70mm cameras. Five of the 10 sites have HDTV cameras. Long-range cameras are used during early phases of ascent to identify and track debris and continue to be used as long as the vehicle is visible.

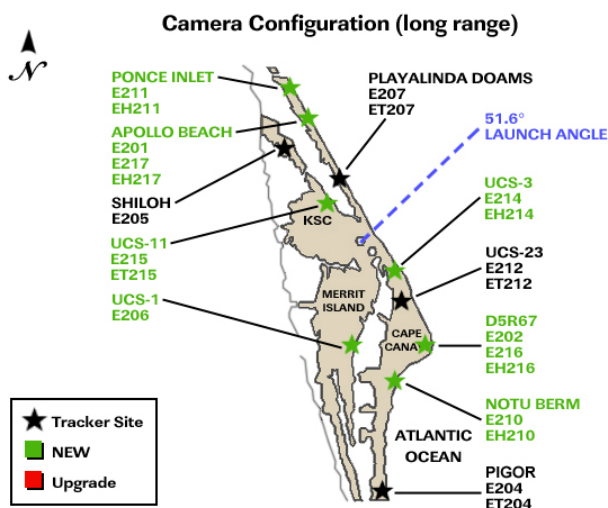

CAMERA RESOLUTION

- Liftoff to 30 seconds: Objects of 1 inch in diameter or larger, 0.5 foot linear accuracy of debris source and impact location
- 30 seconds to 60 seconds: Objects of 3 inches in diameter or larger, 1 foot linear accuracy of debris source and impact location
- 60 seconds to 90 seconds: Objects of 8 inches in diameter or larger, 3 foot linear accuracy of debris source and impact location
- 90 seconds to booster separation: Objects of 15 inches in diameter or larger, 5 foot linear accuracy of debris source and impact location

CAMERA OPERATIONS PLAN

All of the cameras are checked pre-launch, and then activated on launch day to capture the ascent imagery. After launch, the 70mm, 35mm and 16mm films are collected and transported to a central location at the Kennedy Space Center before being flown to an off-site processing facility to be developed and copied for delivery to the Johnson Space Center in Houston and the Marshall Space Flight Center in Huntsville, Alabama. The delivery occurs in two steps: one delivery the day after launch and the second delivery two days after launch.

The Quick Look video imagery – HDTV and other formats – is collected and distributed within the first few hours after launch and provided to the image analysis facilities at Kennedy, Johnson and Marshall via a mirrored server available for review anywhere between one and eight hours after launch.

About one hour after launch, the Quick Look imagery consists primarily of views from the short-range cameras and is reviewed by all of the imagery analysis teams. Quick Look imagery consisting of HDTV imagery from the medium and long-range sites will be retrieved and made available to the imagery analysis teams and

Thermal Protection System experts approximately eight hours after launch.

TAKING THE HIGH GROUND ON ASCENT IMAGING

NASA has implemented use of an aircraft-based imaging system taking advantage of agency WB-57 aircraft based near the Johnson Space Center in Houston. The WB-57 Ascent Video Experiment (WAVE) will be used on an experimental basis during the first two post-Columbia Space Shuttle flights and provide both ascent and entry imagery to enable better observation of the Shuttle on days of heavier cloud cover and areas obscured from ground cameras by the launch exhaust plume. WAVE was initiated to develop the technical and operational capabilities of obtaining video of the Shuttle during launch from an aircraft, which will supplement ground cameras to obtain three useful views.



WAVE includes a 32-inch ball turret system mounted on the nose of each WB-57 aircraft. The turret houses an optical bench providing installation for both High Definition Television and infrared cameras. Optics consists of an 11-inch-diameter, 4.2 meter fixed focal length lens. The system can be operated in both auto track and manual modes from a command and control system in the cockpit, which includes monitors for all three cameras, switch panels and joysticks. All footage will be recorded on board and returned for processing and evaluation shortly after the Shuttle launch.

The two imaging cameras are a HDTV color camera (Panasonic AK-HC900) and a Near Infrared camera (Sensors Unlimited SU640SDV 1.7RT/RS-170). Both share a Celestron fixed

field-of-view telescopic lens. In addition, a National Television Standards Committee (NTSC) color acquisition camera will be used to track the Shuttle during ascent.

Approximately two days before launch the two WB-57 aircraft will fly from Ellington Field in Houston to Patrick Air Force Base in Florida.

Two and a half hours before launch, the aircraft will take off from Patrick and enter a holding pattern. One will be positioned north of the Shuttle's flight path and one will be positioned south. The aircraft will be in communication with a WAVE Operations Officer in the Range Operations Control Center who in turn will be in communication with the chairperson of the imagery team in the Launch Control Center.



Twenty minutes before launch the aircraft will enter their final circuit, and about five minutes before launch will begin recording video. The WAVE requirement is for imagery acquisition from 60 seconds after liftoff to 15 seconds after booster separation. However, plans are for the aircraft to track the vehicle from liftoff through Main Engine Cut Off (MECO), which occurs 8 1/2 minutes later. The two aircraft should be about 23 miles (37 kilometers) from the Shuttle at booster separation.

After launch, the aircraft will return to Patrick, and the video will be retrieved from the onboard recorders and transported to Kennedy. There it

will be loaded on the mirrored servers about eight hours later.

The WB-57 aircraft operate out of Ellington Field near Houston under direction of JSC. They are the only two WB-57's still flying today. Identified as NASA 926 and NASA 928, the high altitude weather aircraft can fly day and night with a range of approximately 2,500 miles. Two crewmembers in pressurized suits pilot the plane to altitudes in excess of 60,000 feet and the aircraft can carry a payload of about 6,000 pounds.

RADAR TRACKING

For future Shuttle missions, a new wideband and Doppler radar tracking system has been implemented for adequate detection of debris during launch and ascent. Three radars now will digitally record tracking data of the Shuttle from launch until signal is lost with the primary timeframe of interest being launch plus 60 seconds to launch plus two minutes.

Data from each radar site will be stored on a hard disk and backed up on CDs/DVDs, as will be the boresight video used by the radar operators to help track the vehicle.

The three radar systems that will be in place for launch include one C-band and two Doppler X-band.

The Wideband Coherent C-band Radar provides high spatial resolution of debris events, and can detect debris events within the Shuttle vehicle stack. This radar – called the Navy Midcourse Radar – formerly was located at Roosevelt Roads Naval Station in Puerto Rico. It now resides at the site formerly occupied by the National Center for Atmospheric Research, north of Kennedy.



Wideband, Coherent C-Band Radar
3MW peak transmit power
0.5 M range resolution @ 500 Mhz WB LFM
15.24 M dish diameter

RTF_VI_0019.png

The two Weibel Continuous Pulse Doppler X-band Radars provide velocity and differential Shuttle/debris motion information. Correlation of these two data sets over the three geometries provided for the debris radar system optimizes the insight and probability of detection for very faint debris targets. These radar systems will be located on ships – one mounted on a booster recovery ship downrange of the launch site, and the other on a ship south of the ground track.

The radars are capable of resolving debris at or greater than observed signal strength of minus 50 decibels per square meter (dBsm). Shuttle debris sources have been characterized as typically falling within in the minus 30 dBsm to minus 45 dBsm range. The X-band and the C-band radars were tested in August 2004 during the launch of the Delta II/Messenger spacecraft from the National Center for Atmospheric Research (NCAR) site intended to permanently house the systems.



Continuous Pulse Doppler X-Band Radar
 1.6 KW peak transmit power
 0.14 M/S Doppler velocity resolution
 4 x 4 M reflector size

RTF_VI_020.png

The radar data will be analyzed at the NCAR site with the C-band data being available in near real-time, while the X-band data (screen captures) will be sent from the ships via satellite link to the NCAR site. The southern ship is expected back in port 6 hours after launch, and the data will be transported immediately to the NCAR site.

WING LEADING EDGE INSTRUMENTATION

Though impact monitoring is not a requirement for future Shuttle flights, NASA chose to incorporate sensors along the Orbiter wing leading edges to compliment Thermal Protection System inspection by measuring, recording, and transmitting acceleration data to a laptop computer on the flight deck for early transmission to Mission Evaluation Room engineers in the Mission Control Center.

Each wing now has 88 sensors embedded behind the protective Reinforced Carbon-Carbon panels. Sixty-six acquire acceleration data and 22 gather temperature measurements during the Shuttle's launch phase. The temperature sensor data is used to calibrate the impact sensors.

Sensor units made up of three accelerometers, an internal and external temperature sensor and

battery will measure, record and transmit acceleration and temperature data, along with battery voltage to a laptop computer in the crew compartment via a combination of relays and cabling.

Prelaunch, the sensor units are loaded with command files that contain the Greenwich Mean Time (GMT) of launch. Shortly before launch, the units enter trigger mode and at liftoff are activated via a G force switch to begin storing and processing ascent accelerometer data stored at 20,000 samples-per-second-per-channel within the unit's internal memory. Temperature and battery voltage data is stored every 15 seconds.

Ten minutes after launch – after the External Tank separates – continuous data collection will stop. Each sensor unit will process the data to determine the peak acceleration forces that particular sensor experienced during ascent. This summary data, once downlinked to the ground, will be screened and compared to threshold criteria to determine whether any potential impact events occurred.

After processing the data, the system will enter on-orbit mode, meaning only six sensor units will collect acceleration, temperature and battery voltage. The other units will become idle. The specific units in each mode will rotate throughout the flight in order to maximize the battery life of the sensors.

About 1½ hours after launch (completion of the post post-insertion timeline), the crew will connect the wing leading edge system laptop to the onboard computer network and the software will begin to download data from each sensor unit. Commands are sent through the laptop to the 44 sensor units and will download acceleration, temperature and voltage data for each sensor.

A small amount of raw data from liftoff also will be downloaded to be used as a baseline for calculations on the ground. Throughout the

remainder of the flight, the sensor units will be commanded every six hours to download G force peaks, time of occurrence, voltage and temperature files.

As the data files are written to the laptop, they will be extracted from the laptop via ground control by operators in Mission Control and placed on a server for access and evaluation by experts.

Based on the data evaluation of summary data, additional raw data can be requested for areas of interest. Raw data can also be requested based on findings from telemetry or other imagery sources. A command will download the specific time period needed for further evaluation. Data from each sensor unit is downloaded at a rate equivalent to two minutes for .5 second of raw data to the laptop, so a complete set of raw data will not be downloaded to the laptop.

Post-landing, ground operations personnel at Kennedy will download the remaining raw data for archival and analysis.

WING LEADING EDGE IMPACT DETECTION SYSTEM

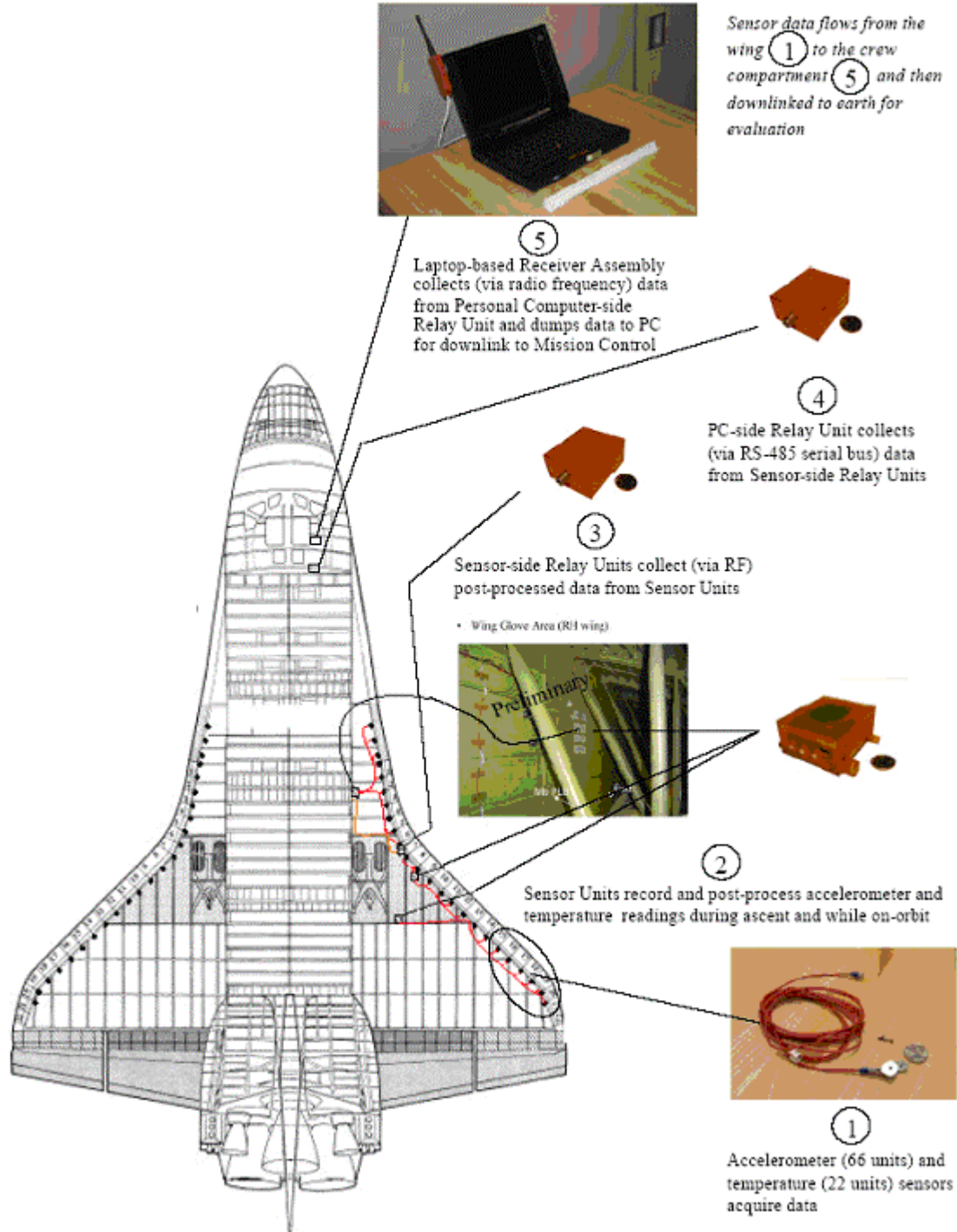

ENHANCED SHUTTLE-BASED CAMERA VIEWS

New and modified cameras on the Space Shuttle solid rockets, External Tank and on Discovery will greatly increase the views available to verify that there is no hazardous debris or damage during ascent.

The cameras increase the capability to monitor the ascent environment, including debris, and verify the health of the Shuttle's Thermal Protection System and the redesigned portions of the External Tank.

Enhancements include reinstating previously used digital cameras on the Shuttle Solid Rocket Boosters; adding a new video camera to the External Tank; adding a new remote electronic still camera on the underside of the Shuttle to replace a previous film camera in that location; and creating new procedures for crew handheld digital photography of the tank. Handheld cameras used by crewmembers also have been modified to allow them to take digital images that can be processed onboard the Shuttle as well for transmission to the ground.

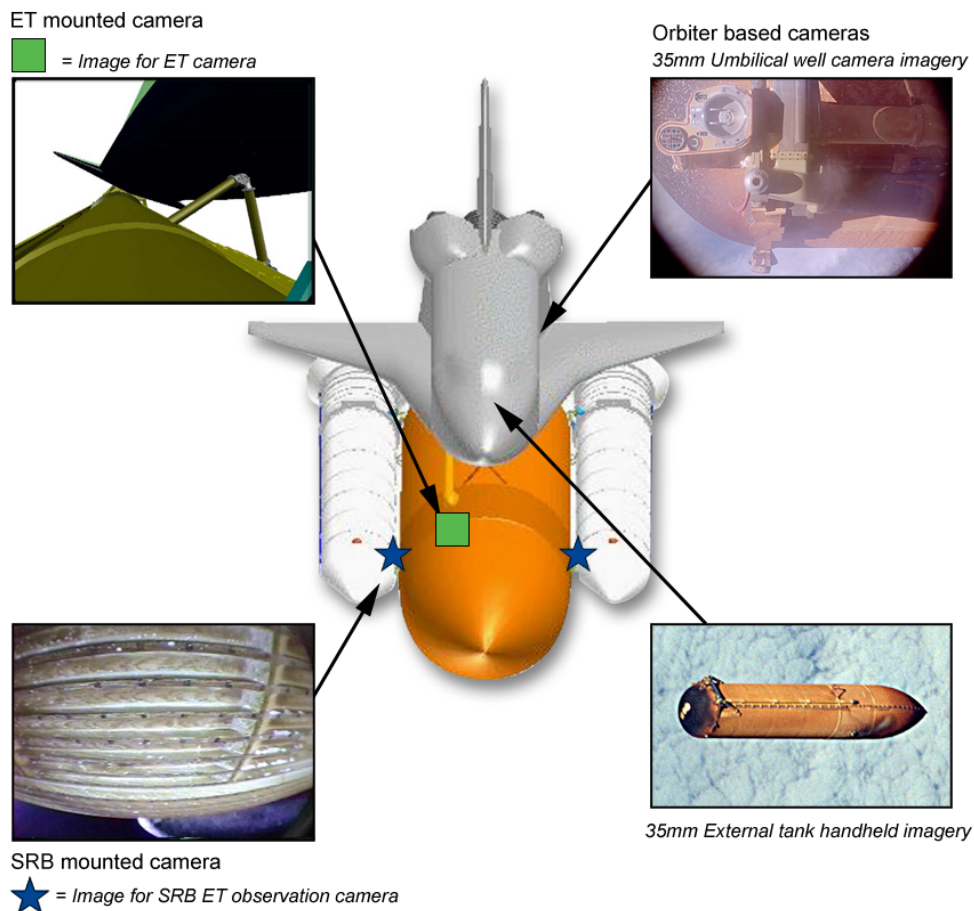

Cameras on the Space Shuttle boosters, External Tank and Orbiter

Together, these steps are part of a project known as the Enhanced Launch Vehicle Imaging System (ELVIS). Several new and modified cameras will fly on Discovery's Return to Flight Space mission, STS-114, while additional steps will be phased in over several future flights.

Also on STS-114, a new handheld digital camera and flash will be available to spacewalkers. The digital camera can be used to take electronic images of any exterior surfaces of the Shuttle while spacewalking.

Together, these measures respond to two recommendations made by the Columbia Accident Investigation Board (CAIB).

The tank-mounted camera provides supplementary imaging to that gained through in-flight inspection with the Orbiter Boom and Sensor System to satisfy recommendation R3.4-3. That recommendation called for NASA to provide a capability to obtain and downlink high-resolution images of the underside of the Orbiter wing leading edge and forward section of both wings' thermal tiles. On later Shuttle flights, beginning as early as STS-115, additional cameras added to the solid rockets will provide better views of the wings during ascent.

The use of handheld digital cameras by the crew to document the External Tank after it is jettisoned and the new electronic still camera on the Orbiter underside during STS-114 satisfy

recommendation R3.4.2, which called for NASA to provide a capability to obtain and downlink high-resolution images of the tank after it has separated from Discovery.

EXTERNAL TANK-MOUNTED CAMERA

A television camera has been installed on the exterior of the External Tank located several feet above the right bipod area in the liquid oxygen feedline fairing housing. The camera and associated equipment are the same as used on one previous Space Shuttle mission as a technology demonstration – STS-112 in October 2002. However, the position and view of the camera have been changed to provide greater visibility of the Shuttle's underside and tank.

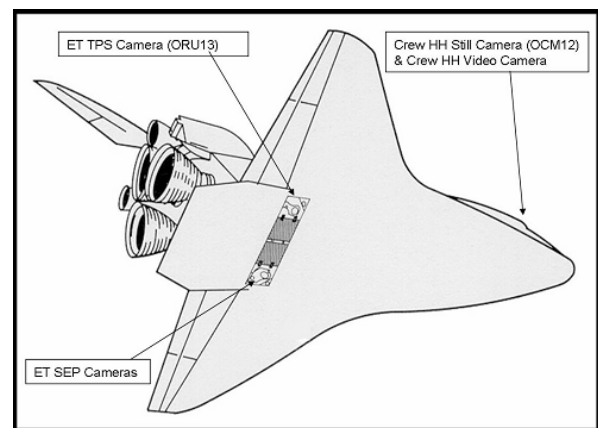

Shuttle Orbiter-Based Photography for STS-114 Ascent

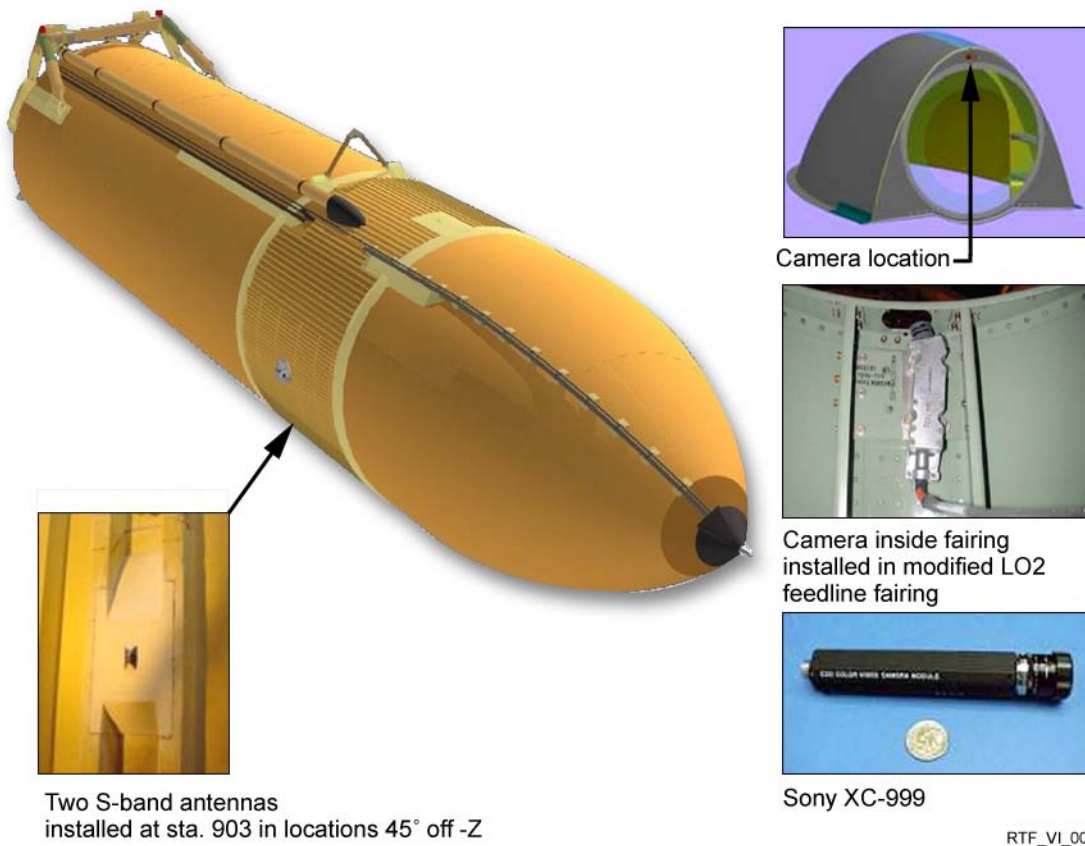

External Tank Camera Overview

The camera is a Sony XC-999 secured in a modified, space-hardened housing. It is about the size of two C batteries laid end-to-end and is of a type commonly referred to as a "lipstick" camera. The camera's views will be transmitted to the ground in real time via the ground communications station at Merritt Island, Fla., during the Shuttle's climb to orbit.

The transmission occurs through an electronics package located within the central part (intertank) of the ET, which

joins the oxygen and hydrogen tanks. The electronics box houses batteries, a 10-watt transmitter and other equipment. The signal is sent to the ground via antennas located on the exterior back side of the tank, almost directly opposite the camera's location.

The new ET camera is expected to remain in the same configuration as used during STS-114 for all subsequent missions.

SOLID ROCKET BOOSTER CAMERAS

Previously used cameras – one on the left solid rocket and one on the right – have been reinstated to provide views of the ET intertank for STS-114. The cameras are located in the same locations as on several previous Shuttle flights. The cameras are located just below the nosecone of each booster and do not provide real-time views during launch. Their imagery is recorded for playback after their retrieval from the Atlantic Ocean.

Future plans, beginning several missions after STS-114, include installing two additional cameras on each booster. One camera will be located at the ET attach ring, about one-quarter of the way up each rocket. Another camera will be added to the forward skirt of each booster, where each rocket's nose cone and main body intersect.

The forward skirt cameras will look aft to provide views of the Shuttle wing leading edges. The ET attach ring cameras will look forward to provide views of the wing and fuselage underside tiles. All future cameras will record imagery onboard the rockets for viewing after they have been recovered. They will not provide real-time television views during launch.

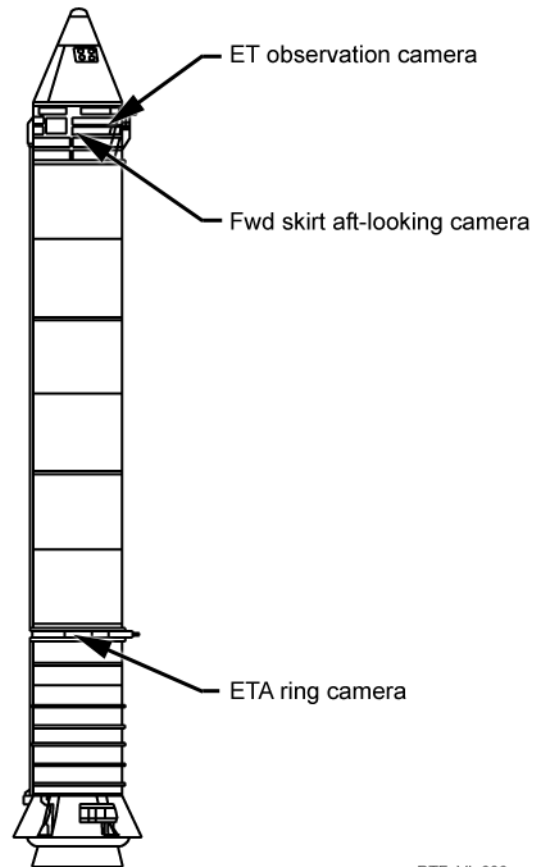

RTF_VI_006.png

SRB-Mounted Cameras

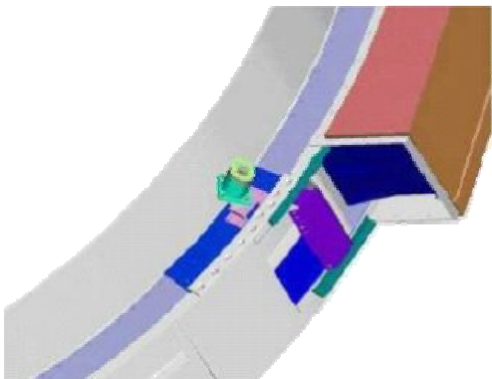

ET Ring Camera Housing Installed

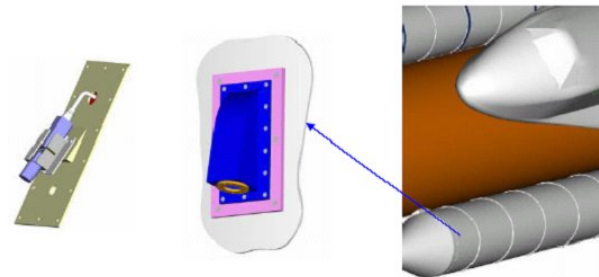

Forward Skirt Aft-Pointing Camera Prototype Housing

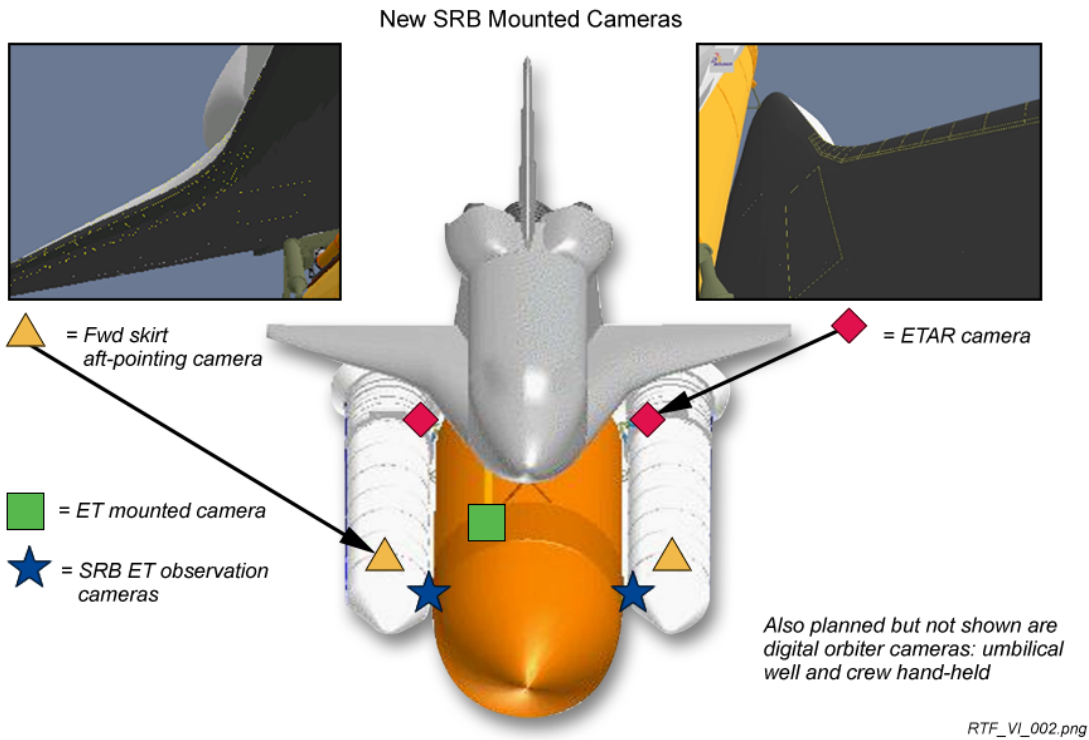

Camera Configuration: Third Flight & Subs

EXTERNAL TANK UMBILICAL WELL DIGITAL STILL CAMERA

For STS-114, a 35mm still camera previously located in the right umbilical well on the underside of the Orbiter on previous Shuttle flights has been replaced with a Kodak DCS760 digital still camera. The new camera will take digital images of the tank after it has separated from the Orbiter and feed them to a laptop computer in the crew cabin. The crew then will downlink those images to Mission Control for analysis early in the flight.

The left umbilical well will continue to have two film cameras as has been flown on previous missions to gather movie imagery for use in analysis after it has been returned to Earth.

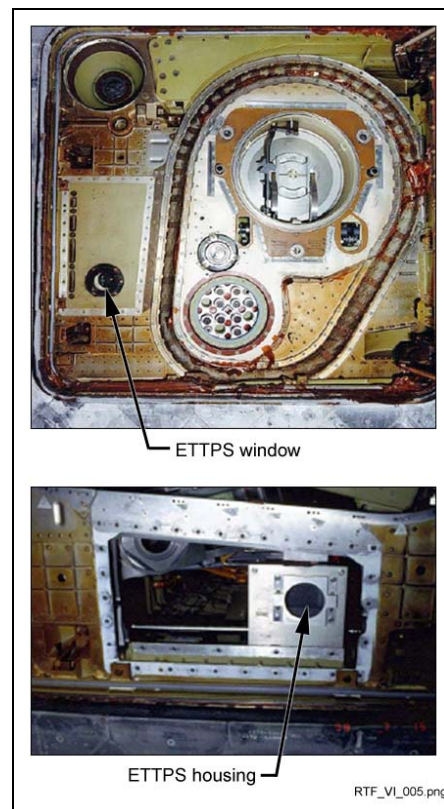

Right-Hand Umbilical Well

CREW HANDHELD PHOTOGRAPHY

The crew's procedures in photographing the External Tank after it has separated from the Orbiter have been modified to use a digital still camera Kodak DCS760. The handheld digital camera has been flown on many past missions, but never before has been used for imagery of the tank after launch. Previously, imagery of the tank was taken by the crew using a handheld film camera and saved for analysis after the Shuttle's return to Earth.

The handheld digital images of the tank taken on STS-114 and subsequent flights will be transferred to a laptop computer and then transmitted to Mission Control early in the mission for analysis. Along with the photography taken by the

umbilical well digital camera, the handheld digital images will assist ground technicians in characterizing the condition of the tank as it was jettisoned. They will assist in characterizing any foam loss and verifying the flight operation of tank design changes that have been made.

To photograph the tank, the Orbiter will be pitched over shortly after the tank has separated to optimize its view from the overhead cabin windows. This maneuver will be done a few minutes earlier during STS-114 than on previous flights. The earlier maneuver will allow the crew to photograph the tank while it is closer, improving the resolution of the imagery.

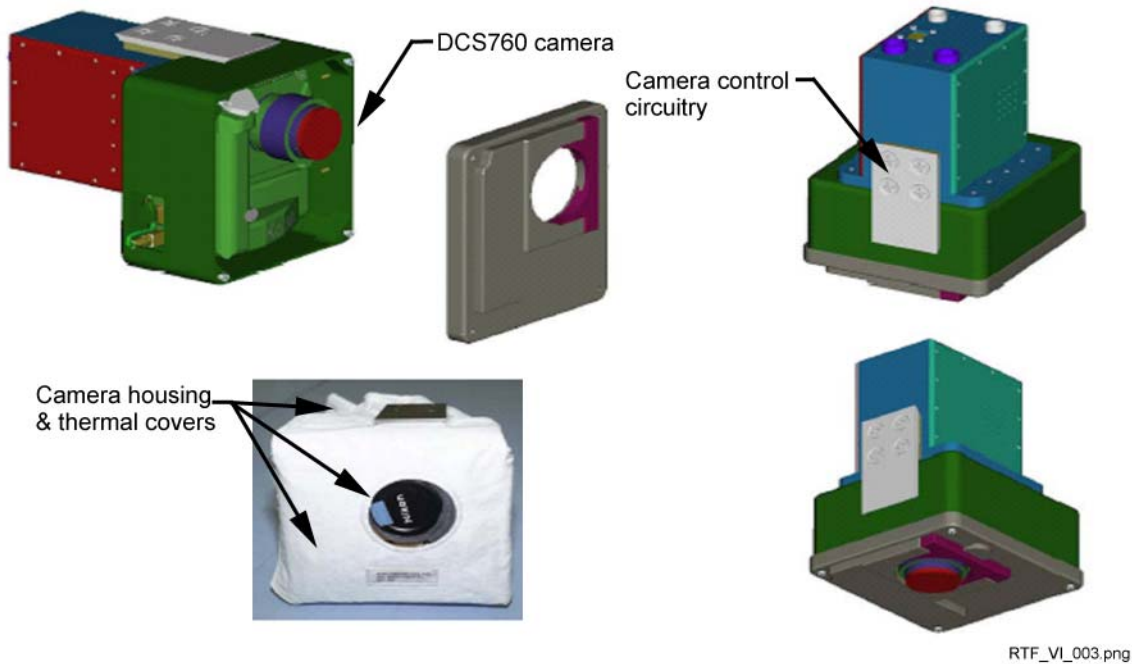

Digital Umbilical Still Camera System

DIGITAL SPACEWALK CAMERA

A new handheld digital camera for use by spacewalkers outside of the vehicle will be flown on STS-114 and subsequent flights. Previously, all handheld cameras used by spacewalkers outside the vehicle had been film cameras. The new Extravehicular Activity (EVA) camera is a Kodak DCS760 camera, the same camera used for digital imagery inside the Shuttle cabin, with some modifications made to equip it for use in the vacuum and extreme temperatures of space. The modifications included a change of lubricants for the camera and a thermal protective covering.

A flash unit also will be available for use with the digital camera during spacewalks. The flash has been modified to remain in an air-tight housing for use in the vacuum of space.

Digital images taken during a spacewalk are stored in the memory of the camera and later brought back inside the Shuttle cabin. Then, they are fed into a laptop computer in the cabin and transmitted to Mission Control. The digital EVA camera may be used to provide images of an inflight repair performed during a mission, to assist an EVA inspection of potential damage or other reasons.

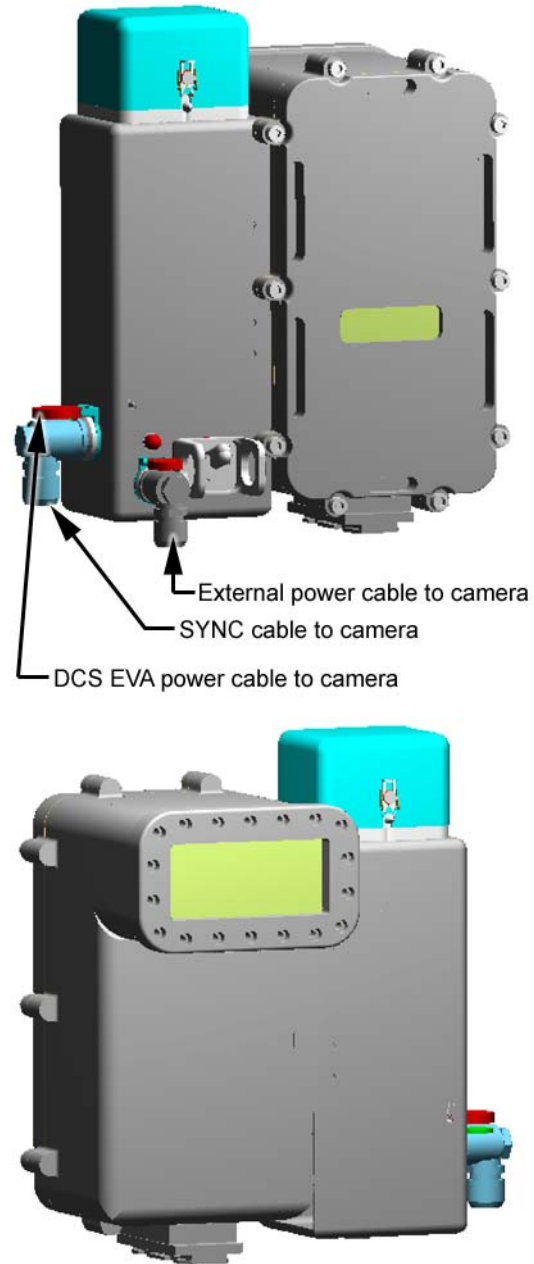

RTF_VI_008.png

EVA Flash Mechanical Design

IN-FLIGHT INSPECTION AND REPAIR

In addition to improved cameras on the ground and on the Space Shuttle, Discovery's astronauts will conduct close-up, in-flight inspections with cameras, lasers, and human eyes.

The primary tool for on-orbit inspection will be a 50-foot-long Space Shuttle robotic arm extension and associated sensors, known as the Orbiter Boom Sensor System (OBSS). While the Shuttle's remote manipulator system (SRMS) is capable of inspecting part of the thermal protection system on its own, the OBSS is needed to extend that reach to all critical areas of the Shuttle's wing leading edge and the Shuttle's belly.

The OBSS was assembled by MD Robotics of Brampton, Ontario, Canada, which manufactures remote manipulator systems for

both the Shuttle and the International Space Station. The OBSS combines two 20-foot-long graphite epoxy cylinders originally manufactured as Shuttle arm replacement parts. At one end of the boom is a modified electrical grapple fixture, and on the other end are the imagery systems. The upper and lower booms are joined by a rigid joining fixture, which has an attached modified flight releasable grapple fixture that will be used to hand the boom from the Station arm to the Shuttle arm during docked operation at the complex. Electrical and data cables run the length of the boom, providing power for the sensors while allowing imagery to be transferred through the Shuttle's wiring system to laptop computers and downlink systems in the crew cabin.

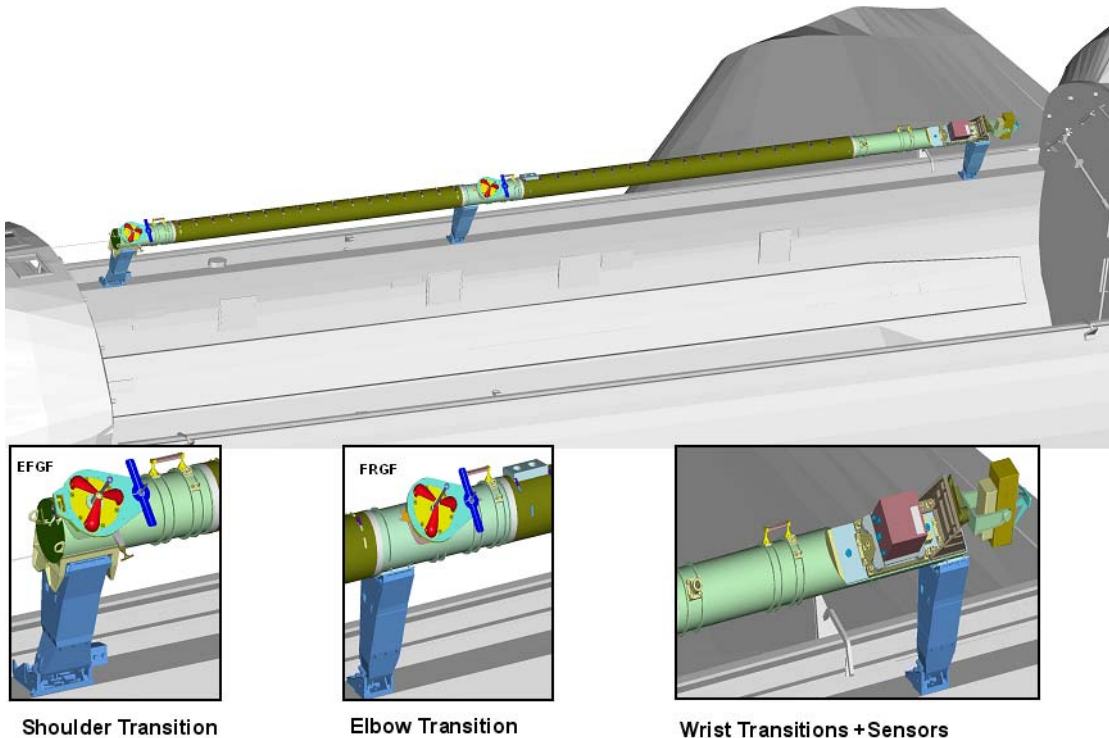

Orbiter Boom Sensor System Installed on Starboard Sill

For STS-114, the imagery systems will include a Laser Dynamic Range Imager (LDRI), a Laser Camera System (LCS) and an Intensified Television Camera (ITVC). The LDRI and ITVC are attached to the boom using a standard Pan Tilt Unit (PTU) that will allow them to be pointed at their targets. The LCS is hard-mounted to the side of the boom just behind the other two instruments.

Manufactured by Sandia National Laboratories, Albuquerque, N.M., the LDRI is comprised of an infrared (not visible to the human eye) laser illuminator and an infrared camera receiver. The LDRI can be used to provide either two- or three-dimensional video imagery data; the two-dimensional imagery may be seen by the Shuttle crew on orbit, but three-dimensional data will need to be processed on the ground after being downlinked via the Shuttle's high-bandwidth Ku antenna system that transmits the video through the Tracking and Data Relay Satellite System (TDRSS).

The ITVC is the same low-light, black-and-white television camera used in the Space Shuttle's payload bay. The two imagery systems may not be used simultaneously.

The LCS, manufactured by Neptec of Ottawa, Ontario, Canada, is a scanning laser range finder developed for use aboard the Space Shuttle. The LCS can be used as a 3D camera or to generate computer models of the scanned objects, accurate to a few millimeters at distances of up to 10 meters. Unlike the LDRI, the LCS data is not video, but instead are files collected on a dedicated laptop.

The data is processed on the ground after being downlinked through the Orbital Communications Adapter (OCA) - a high-speed computer modem that uses the Shuttle's Ku antenna system to transmit the data through the TDRSS.

During STS-114, Discovery is scheduled to rendezvous and dock with the International Space Station on Flight Day 3. As the Shuttle pursues the Station on Flight Day 2, the astronaut crew will conduct a thorough inspection of Discovery's wing leading edges and nose cone using the OBSS. Three crewmembers will take turns, working in pairs, to operate the Shuttle's robotic arm from the aft flight deck, unberth the OBSS from its cradles on the starboard side of the payload bay and conduct the inspection.

Since the LDRI and LCS distance to its target must remain within 10 feet to ensure image quality and because the arm and boom must not contact any of the Shuttle's surfaces in the process, the astronauts use a combination of automated and manual arm operation modes. The surveys are done using automatic mode with the astronauts monitoring its progress. The astronauts will use the manual arm operation mode to move the OBSS from the end of one sequence to the start of the next.

Mission planners expect the Flight Day 2 survey of Discovery's wing leading edges and nose cap to take about seven hours to complete, assuming a maximum scan rate of four meters per minute (2½ inches per second). The scans will be broken into 60- to 90-minute blocks, or sequences, corresponding with specific areas of the Shuttle's thermal protection skin. Engineering experts on the ground will review the data both in real time and after processing on the ground to identify any areas that need additional scrutiny.

Discovery's robotic arm is expected to be used without the boom on Flight Day 2 to conduct video inspections of the upper tile surfaces using the arm's end effector camera. The next day, during the Shuttle's rendezvous with the Station, as Discovery reaches a point 600 feet below the Station, the crew will perform a Rendezvous Pitch Maneuver, a three-quarter-foot per-second backflip, so that its underside faces the Station. The Station crew will use digital still cameras

with 400 and 800 millimeter lenses and a detailed plan to photographically map the Shuttle's underside for about 90 seconds before it continues on to docking. The images will be sent to Earth for inclusion in the collection of data that will be used by the Mission Evaluation Room (MER) and Mission Management Team (MMT) to evaluate the condition of the thermal protection system. That data will be part of the compilation of imagery to allow mission managers to make decisions on how the mission should proceed.

After docking and welcome ceremonies are complete, Shuttle and Station crewmembers will work together, lifting the OBSS out of the cargo bay using the Space Station Remote Manipulator System (SSRMS) and handing it to the Shuttle arm for use in additional surveys the following day. The Station arm, also known as Canadarm2, will be brought into play because the geometry of the combined Shuttle-Station configuration results in obstructions that prevent the Shuttle arm from maneuvering the OBSS out of its cargo bay cradles. The STS-114 flight plan identifies Flight Day 4 as an additional day for docked surveys, if required, using the OBSS, either to complete parts of the survey that time would not allow on Flight Day 2, or to supplement the survey with "stop-and-stare" scans of sites of potential interest. Some of Discovery's crew will reserve time for these detailed inspections for the last half of Flight Day 4 while other crewmembers are making preparations for the first spacewalk, which will, among other things, test thermal protection system techniques, tools and devices.

After the in-flight data, images and personal reports from the crew are relayed to the ground, engineers and imagery experts will process and integrate the information with that recorded during launch and the climb to orbit. The Space Shuttle Program's Systems Engineering and Integration Office (SE&I) will work closely with the MER to review and evaluate the information and provide separate damage assessments for

tiles and the reinforced carbon-carbon panels of the wing leading edges and nose cap. Their evaluations and assessments will be presented to the MMT, which is expected to decide by Flight Day 6 whether a spacewalk is needed for an up-close, in-person inspection that could be followed by a hands-on repair.

At this writing, spacewalk designers are actively evaluating a variety of options for placing astronauts close enough to allow detailed inspection and repair of suspected thermal protection system damage. Several different challenges need to be met to enable a spacewalker to perform these tasks.

THERMAL PROTECTION SYSTEM ON-ORBIT REPAIR TECHNIQUES

Prevention is NASA's first line of defense against damage to the Space Shuttle's TPS, which defends the vehicle and its occupants against the 3,000-degree Mach 25 buffeting of re-entry. But quelling debris from the external tank and solid rocket boosters cannot eliminate all the threats to the Shuttle's tiles and reinforced carbon-carbon wing leading edge panels. On orbit, orbital debris (or space junk) and micrometeoroids also are capable of causing damage.

Although the STS-107 crew had no tested tools or materials available to address the type of damage inspectors have deduced was present during Columbia's re-entry, NASA lost little time in the months following the accident beginning work on viable repair strategies. A Vehicle Inspection and Repair Orbiter Flight Techniques Panel "tiger team" of experts from the TPS engineering, mission operations and extravehicular activity organizations at JSC, working in collaboration with their counterparts at other NASA centers and with contractors, made significant progress in identifying the issues that needed to be addressed, and in devising means of addressing them. The tiger team was able to define preliminary criteria for damage that must be

repaired on orbit, identify all critical areas that must be reached for inspection, identify candidate on-orbit repair materials capable of withstanding the stress of entry, and design initial tools and techniques that would allow spacewalkers to repair critical damage to both tiles and reinforced carbon-carbon segments.

In November 2003, direct responsibility for leading these development projects was assumed by the Space Shuttle Program. The Space Shuttle Program divided and assigned this work to four separate but interactive project teams in its

Orbiter Project Office. These teams were given responsibility for managing design and development of an orbiter boom and sensor system, a set of wing leading edge sensors, a tile repair system, and an RCC repair system. The work of all these teams is ongoing, and is divided into two phases: systems that can be ready to meet the CAIB recommendations in time for the Shuttle's Return to Flight, and long-range projects that have the potential to further enhance the detection and repair needs if given more time.

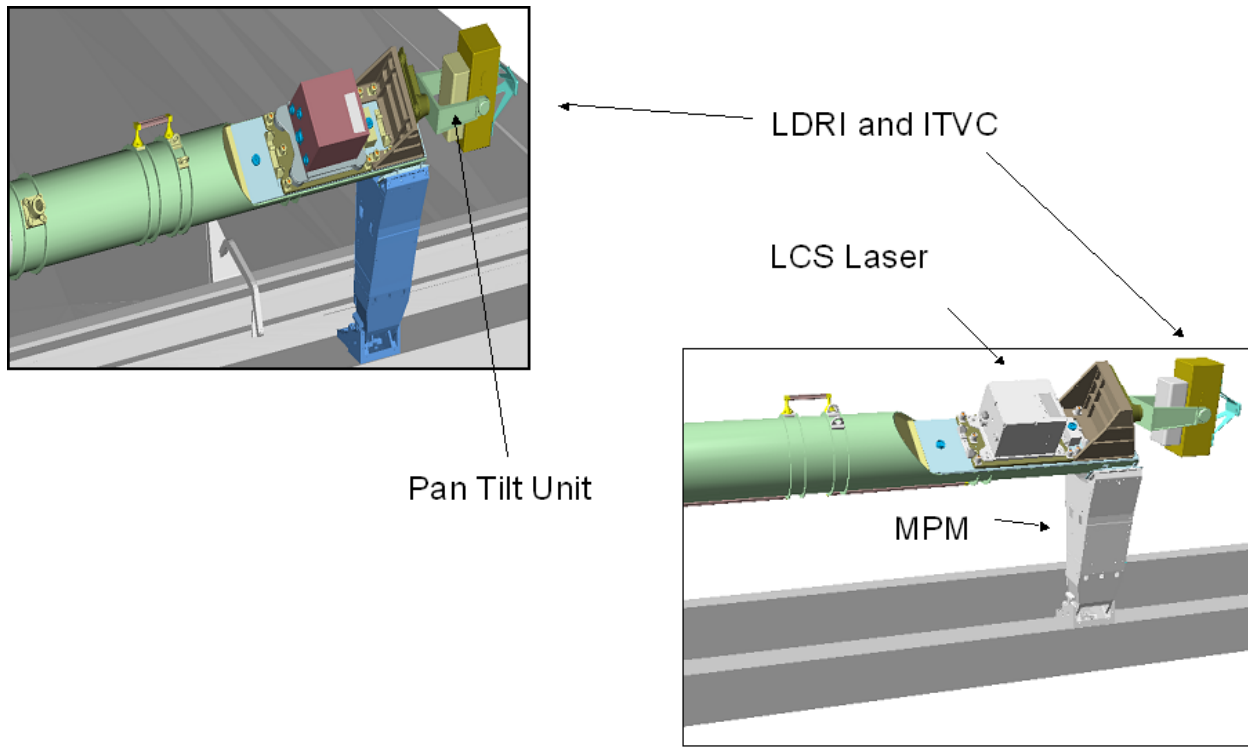

Inspection Sensors

The TPS repair systems developed to date fall into two basic categories, mechanical or chemical, and each type has advantages and disadvantages. Mechanical systems rely on prefabricated materials and fasteners that connect them to the Shuttles' existing protection systems. Chemical systems rely on materials that are applied in a raw form and develop a chemical adhesive bond when applied to the existing protection systems; these must cure in place before being subjected to re-entry conditions. Mechanical installation methods can be tested and validated on Earth, while chemical methods will require testing in

space to validate application techniques and material hardening. A Development Test Objective (DTO) for tile repair is being designed for the STS-114 mission, and will test those tile repair tools, techniques and materials that are mature enough in orbit. This DTO will use a series of task boards in the aft section of the Shuttle's cargo bay. The task boards will be returned to Earth for inspection and tests of their ability to withstand the stresses of entry. At this time, three repair methods are scheduled to be tested on STS-114 – two outside the Shuttle in the cargo bay and one inside the crew cabin.

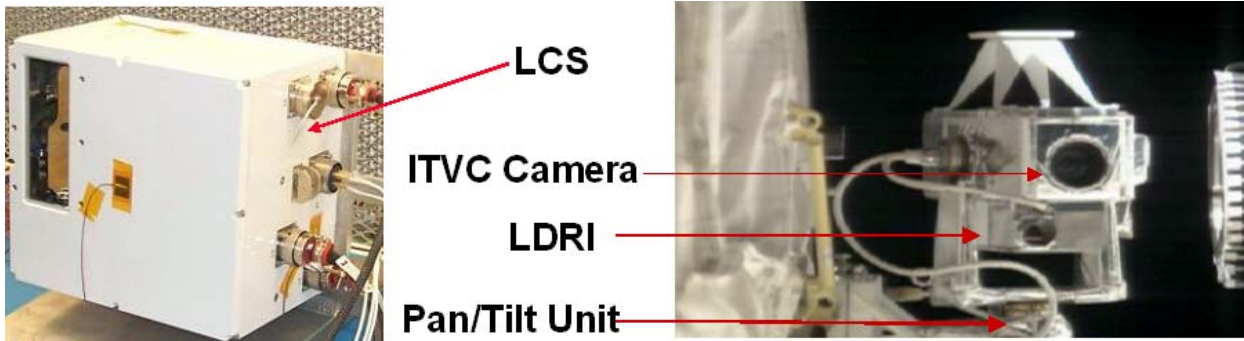

- Neptec Laser Camera System (LCS)
- Triangulates 3D position with a small diameter scanning laser beam
- Sandia Laser Dynamic Range Imager (LDRI)
- Illuminates the FOV with modulated laser light. Images on a camera CCD are processed to provide depth information.
- Designed & flown as an integrated package with an ITVC and pan & tilt unit (PTU)

TILE

Space Shuttle Program managers recently reviewed the progress of tile repair development teams and selected three options for continued short-term evaluation.

The first is a design revived from incomplete 1970s work to develop an ablative material that could fill gaps caused by tiles that were lost or damaged during launch. Ablative materials, like those used on heat shields that protected early space vehicles in the Mercury, Gemini and Apollo programs, are meant to burn away partially during atmospheric re-entry. Engineers revived the '70s formula for a silicone-based, cure-in-place ablative material and further refined it to fill cavities in tile or to substitute for missing tiles.

The silicone-based material, now known as Shuttle Tile Ablator-54 (STA-54), is manufactured in two parts – a base material and a catalyst – and mixed together during application using a Cure-In-Place Ablative Applicator (CIPAA). This applicator system consists of an EVA backpack with tanks to separately contain the base and catalyst components under pressure, paired hoses to transport the components to the damaged area, and an applicator gun that uses a static mixer to combine the materials as they are extruded into a cavity. Astronauts apply the material – which has a consistency similar to cake frosting when dispensed -- using the CIPAA. Since the material is sticky and intended to adhere to tile, tools such as foam brushes and tampers are used to smooth the repair material without sticking. In addition, the ablative material expands when heated, so astronauts will under-fill cavities to protect against excessive expansion that could disturb the normal plasma flow across the Shuttle's tile surface. The STA-54 material cures and hardens over a period of 24 to 48 hours.

The second method is known as emittance wash application, which uses a repair material being developed primarily for shallow tile damage but also is useful as a primer to improve STA-54 adhesion to tile substrate. The silicon tiles used in the Shuttle's thermal protection system both reject heat and insulate. The white silicon substrate provides insulation, while the black reaction-cured glass (RCG) coating rejects heat. The ability of a material to reject heat is measured in terms of its "emissivity." The RCG coating on tiles has a high emissivity value, while the white substrate has a lower emissivity value, especially as temperatures rise. The science behind the emittance wash repair involves replacing a damaged tile's coating to restore its ability to reject the high temperatures of atmospheric entry.

NASA has developed and will test on STS-114 an emittance wash, which is fine-grit silicon carbide (SiC) granules mixed with a room temperature vulcanizing (RTV) material. Using a dauber-like applicator, the emittance wash can be applied to exposed tile substrate. The emittance wash wicks into the tile substrate, providing a strong adhesive bond, and a high emissivity, or heat rejection value. For small, shallow areas of damage, replacing the RCG coating with the emittance wash will restore enough heat rejection capability for safe entry. For larger or deeper gouges, the emittance wash may be used as a primer for STA-54. Its ability to wick into the tile substrate encourages a stronger bond between the tile and the STA-54 repair material, as well as protection along the edges of the repaired area when they are underfilled to allow for ablative swelling.

The third method is a mechanical repair that uses insulating blankets to fill cavities that are then covered by an overlay of carbon silicon carbonate installed using augers that penetrate directly into healthy tiles. The overlay system consists of Saffil insulation blankets, pre-packaged in a variety of shapes and sizes, which provide radiant heat

protection when installed in the cavity. A thin (0.03 inches) overlay cover made of a high-temperature resistant, flexible material such as carbon-silicon carbide -- which can hold its shape as a shield against plasma flow -- is installed over the damaged tile and insulation blanket using augers screwed directly into adjacent healthy tiles. Around the edges, between the overlay and the existing tile, a fabric gasket is used to prevent hot gasses from penetrating beneath the overlay.

The materials and tools for applying either repair system are continuing to be evaluated in laboratory tests, simulated zero-gravity tests and human-thermal vacuum tests. While tests of STA-

54 at ambient atmospheric pressures and temperatures went as expected, the material exhibited a tendency to bubble when applied in a vacuum and temperatures approximating those of space. Materials tests are continuing to evaluate whether STA-54 can be applied in a manner that allows for relatively uniform bubble sizes and distribution throughout a given repair. Both STA-54 and the overlay system have passed preliminary tests in Arcjet facilities that can mimic the heating and dynamic pressure of atmospheric re-entry, but additional testing is continuing.



In the Orbiter Processing Facility, STS-114 Mission Specialist Charles Camarda looks closely at the tiles on Discovery. At left is Cindy Begley, lead EVA flight controller. The tiles are part of the Thermal Protection System on the orbiter.

REINFORCED CARBON-CARBON

Space Shuttle Program managers recently reviewed the progress of RCC repair development teams and selected two options for continued short-term evaluation. One option is a pre-ceramic polymer designed to repair small cracks and coating losses on the exterior of the RCC panel, while the other is mechanical in nature, designed for repairing holes that penetrate through an RCC panel.

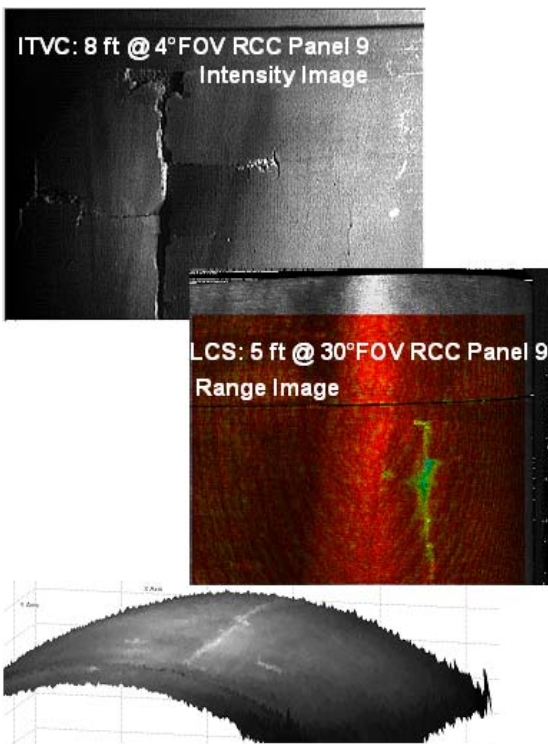

- ITVC
- Good flexibility as a general survey tool
- Low resolution, inherent image defects
- Able to detect small defects under specific conditions
- LCS
- Provides very detailed 3-dimensional information
- Shown to operate while translating
- LDRI
- Valuable performance as both a 2D & 3D imager
- Picture shows an intensity image laid on top of range image, although it appears fuzzy to the untrained eye, it gives a wealth of data

The crack repair option uses a pre-ceramic polymer sealant impregnated with carbon-silicon carbide powder, together known as NOAX (short for Non-Oxide Adhesive eXperimental). It is designed to fix the most likely type of damage caused by small pieces of foam coming off the redesigned external tank. NOAX can be used at any RCC location, and does not require any physical modification of the RCC before affecting a repair. It is expected to repair cracks or coating losses up to .02 inches wide and 4 inches long, but cannot be used to repair holes. The repair procedure for this material may require a separate heating capability for application and/or curing. This could be accomplished by an astronaut installing an EVA heater to the damaged area of the RCC to prepare the surface for application of the repair material. A selection of hand tools similar to putty knives would be used to work the material into the crack and to smooth the surface of the repair. Early testing on the ground has shown promising results that heating the damaged area and the material may not be required to achieve the desired.

The mechanical “plug” option consists of round, thin (0.03-inch), flexible 7-inch-diameter carbon-silicon carbide cover plates that are designed to flex up to 0.25 inch to conform to the shape of the wing leading edge RCC panels, and a hardware attachment mechanism similar to a toggle bolt, known as TZM. Twenty to 30 unique plug sizes and shapes are needed to provide coverage for all possible RCC panel damage locations. If the hole is not as large as one inch, the astronauts would use a Pistol Grip Tool (PGT) and special bit to drill out the hole. Astronauts would select the appropriate cover plate at the work site, connect the plate to a TZM bolt, and then insert the folded bolt through the hole. By tightening a fastener that extends through the cover plate to the TZM bolt, the astronaut will unfold the toggle inside the RCC panel and tighten it until the cover plate conforms to the exterior shape of the RCC



In the Orbiter Processing Facility, members of the STS-114 crew take a close look at the Reinforced Carbon-Carbon on the wing's leading edge on Discovery.

panel. After ensuring any gap between the cover plate and the RCC panel is within tolerances, the astronaut would apply a thin bead of uncured NOAX sealant around the edge of the repair as extra protection against plasma infiltration. The plug concept has the potential to repair damage up to six inches in diameter.

ACCESS

Access to damaged sites will be accomplished through a variety of means, depending on whether the Shuttle is at the International Space Station.

On Station missions, techniques are being developed that will allow robotic arm operators to undock and reposition the Shuttle for a Station-based spacewalk repair. Spacewalkers would be positioned at the work site by the Station's robotic arm using a Portable Articulating Foot Restraint (PAFR).

For non-Station missions, access may be gained through the use of the Shuttle's robotic arm or the arm and its 50-foot boom extension, or through use of the Shuttle Aid for Extravehicular Rescue (SAFER). A variety of candidate work platforms are in preliminary stages of development and continue to be evaluated.

FUTURE WORK

Several other repair concepts have been proposed for both tile and RCC repair. These include flexible adhesive patches and small area repair plugs for RCC, and hardening of the existing tile system coating. Researchers at a variety of NASA centers and contractor laboratories are continuing to develop these approaches for possible use in the next several years.

CONTINGENCY SHUTTLE CREW SUPPORT (CSCS) – 'SAFE HAVEN'



NASA initiated a study to determine the feasibility of rescuing a stranded Space Shuttle crew at the International Space Station in the unlikely event damage would prevent the safe re-entry of the vehicle. The ISS Program conducted an extensive evaluation of the Station's capability to provide provisions and life support to a Shuttle crew as part of an agency self-imposed contingency case that would ensure a second Shuttle was far enough along in processing to be launched to rescue the stranded crew.

This Contingency Shuttle Crew Support (CSCS) – also known as safe haven – would be used only as a last resort to return the crew of a critically damaged Shuttle. In the unlikely event all new safety measures were unsuccessful, and a Shuttle docked to the ISS is deemed unsafe for return to Earth, NASA would consider using CSCS to rescue the crew.

The most significant part of the flight rationale for a safe Return to Flight has been the work to modify the Shuttle's External Tank to reduce as much as possible the shedding of debris that could harm a Shuttle during launch. Additionally, NASA developed a suite of inspection capabilities and repair techniques that will detect critical impacts and provide repair options to the crew should any damage occur.

CSCS is one of NASA's "raise the bar" initiatives added to the 15 Columbia Accident Investigation Board recommendations for Return to Flight. Under the guidance of the Space Flight Leadership Council, the ISS

and Space Shuttle Programs have made the necessary preparations for this option to be available for the first two Shuttle flights (STS-114 & STS-121).

Those preparations include investigating ways to appropriately build up critical systems and consumables onboard the Station. The plan is being reviewed by the Return to Flight Task Group even though it was not a formal Return to Flight recommendation by the CAIB.

Data collected from the first two missions should provide enough information to validate the tank's redesign and, combined with other additions and inspection tools, could alleviate the need for processing a second orbiter to support CSCS. However, no final decision on whether to continue to pursue CSCS capability for future flights will be made until the data from STS-114 and STS-121 is scrutinized.

The CSCS scenario allows the visiting crew of a critically damaged Shuttle to live onboard the Space Station until a rescue Shuttle can be launched. The crews would transfer all of the consumables from the damaged Shuttle to the Station. Once the Shuttle consumables are depleted, the unmanned Shuttle will be remotely commanded to undock by Mission Control in Houston and burn up in the Earth's atmosphere.

In the meantime, the next Space Shuttle in the launch processing flow at the Kennedy Space Center in Florida will become the rescue vehicle and work will focus on it launching and arriving at the Station before consumables run out. The number of days the Station can support a stranded Shuttle crew would be determined, in part, by the consumables already on board, plus

what is brought up with the Shuttle. The level of consumables onboard the Station, including food, water, oxygen and spare parts, will be reviewed and provided up until the day of the first Shuttle launch to define the CSCS capability for that particular mission.

NASA's plan of crew support in a contingency calls for a subset of the STS-121 crew to support STS-114 and a subset of the STS-115 crew to support STS-121. The contingency flights are designated STS-300 and STS-301, respectively. The crewmembers that would support a CSCS case are:

STS-300

Steve Lindsey, Commander and backup Remote Manipulator System operator

Mark Kelly, Pilot and prime Remote Manipulator System operator

Mike Fossum, Mission Specialist 1 and Extravehicular 2

Piers Sellers, Mission Specialist 2 and Extravehicular 1

STS-301

Brent Jett, Commander

Chris Ferguson, Pilot and backup Remote Manipulator System operator

Joe Tanner, Mission Specialist 1, Extravehicular 1 and prime Remote Manipulator System operator

Dan Burbank, Mission Specialist 2 and Extravehicular 2

The Soyuz spacecraft at the Space Station will remain the emergency rescue vehicle for the ISS Expedition crew.

Detailed biographies on the astronauts is available at: <http://www.jsc.nasa.gov/Bios/>

CAIB RECOMMENDATIONS



When the [Columbia Accident Investigation Board](#) issued its final report in August 2003, NASA already had committed to responding to its recommendations. Additionally, the Space Shuttle Program imposed upon itself a list of actions above and beyond the CAIB findings to ensure the Shuttle would fly safer than ever before through the rest of its planned life to

complete assembly of the International Space Station.

The independent 13-member Board offered 29 total recommendations in its 248-page report, including 15 to be addressed before Return to Flight. The report was the result of a seven-month investigation by the members, approximately 120 investigators, 400 NASA and contractor employees, and more than 25,000 searchers who recovered Columbia's debris.



From left to right are board members G. Scott Hubbard, Dr. Douglas D. Osheroff, Dr. James N. Hallock, Maj. General John Barry, Dr. Sally Ride, Rear Admiral Stephen Turcotte, Board Chairman Admiral (retired) Hal Gehman, Brig. General Duane Deal, Steven Wallace, Maj. General Kenneth W. Hess, Dr. John Logsdon, Roger E. Tetrault, and Dr. Sheila Widnall.

The 15 CAIB Return to Flight recommendations:

() - References the report section for which each recommendation applies.

1. Upgrade the imaging system to be capable of providing a minimum of three useful views of the Space Shuttle from liftoff to at least Solid Rocket Booster separation, along any expected ascent azimuth. The operational status of these assets should be included in the Launch Commit Criteria for future launches. Consider using ships or aircraft to provide additional views of the Shuttle during ascent. (R3.4-1)
2. Provide a capability to obtain and downlink high-resolution images of the External Tank after it separates. (R3.4-2)
3. Provide a capability to obtain and downlink high-resolution images of the underside of the Orbiter wing leading edge and forward section of both wings, Thermal Protection System. (R3.4-3)
4. For missions to the International Space Station, develop a practicable capability to inspect and effect emergency repairs to the widest possible range of damage to the Thermal Protection System, including both tile and Reinforced Carbon-Carbon, taking advantage of the additional capabilities available when near to or docked at the International Space Station. The ultimate objective should be a fully autonomous capability for all missions to address the possibility that an International Space Station mission fails to achieve the correct orbit, fails to dock successfully, or is damaged during or after undocking. (R6.4-1)
5. Upgrade the imaging system to be capable of providing a minimum of three useful views of the Space Shuttle from liftoff to at least Solid Rocket Booster separation, along any expected ascent azimuth. The operational status of these assets should be included in the Launch Commit Criteria for future launches. Consider using ships or aircraft to provide additional views of the Shuttle during ascent. (R3.4-1)
6. Provide a capability to obtain and downlink high-resolution images of the External Tank after it separates. (R3.4-2)
7. Provide a capability to obtain and downlink high-resolution images of the underside of the Orbiter wing leading edge and forward section of both wings' Thermal Protection System. (R3.4-3)
8. Modify the Memorandum of Agreement with the National Imagery and Mapping Agency to make the imaging of each Shuttle flight while on orbit a standard requirement. (R6.3-2)
9. Test and qualify the flight hardware bolt catchers. (R4.2-1)
10. Require that at least two employees attend all final closeouts and intertank area hand-spraying procedures. (R4.2-3)
11. Kennedy Space Center Quality Assurance and United Space Alliance must return to the straightforward, industry-standard definition of "Foreign Object Debris" and eliminate any alternate or statistically deceptive definitions like "processing debris." (R4.2-5)

12. Adopt and maintain a Shuttle flight schedule that is consistent with available resources. Although schedule deadlines are an important management tool, those deadlines must be regularly evaluated to ensure that any additional risk incurred to meet the schedule is recognized, understood, and acceptable. (R6.2-1)
13. Implement an expanded training program in which the Mission Management Team faces potential crew and vehicle safety contingencies beyond launch and ascent. These contingencies should involve potential loss of Shuttle or crew, contain numerous uncertainties and unknowns, and require the Mission Management Team to assemble and interact with support organizations across NASA/Contractor lines and in various locations. (R6.3-1)
14. Prepare a detailed plan for defining, establishing, transitioning, and implementing an independent Technical Engineering Authority, independent safety program, and a reorganized Space Shuttle Integration Office as described in R7.5-1, R7.5-2, and R7.5-3. In addition, NASA should submit annual reports to Congress, as part of the budget review process, on its implementation activities. (R9.1-1)
15. Develop an interim program of closeout photographs for all critical sub-systems that differ from engineering drawings. Digitize the closeout photograph system so that images are immediately available for on-orbit troubleshooting. (R10.3-1)

STS-114 OVERVIEW:

SHUTTLE INSPECTION, STATION RESUPPLY HIGHLIGHT DISCOVERY'S MISSION



The Return to Flight Space Shuttle mission will take America's flagship spacecraft back into orbit more than two years after the Columbia accident. The launch will be a dramatic display of smoke, fire, and sound -- and the fulfillment of a promise made to the families of the Columbia astronauts: that NASA would honor their memory by continuing their quest for knowledge.

Discovery is targeted for launch May 22 with a launch window that extends to June 3 from Launch Pad 39B at NASA's Kennedy Space Center.

Discovery's crew of seven astronauts is led by Commander Eileen Collins (Col., USAF, Ret.), America's first female spacecraft commander. Joining her will be Pilot James Kelly (Lt. Col., USAF), and Mission Specialists Soichi Noguchi (So-wee-chee Nah-gu-chee), representing the Japan Aerospace Exploration Agency (JAXA); Stephen Robinson and Andrew Thomas, both civilian mechanical engineers; Wendy Lawrence (Captain, USN); and Charles Camarda (Kah-mar-da), a civilian aerospace engineer.

Though a veteran astronaut, Collins will fly a mission like no other, a unique test flight that will serve as a foundation for every Shuttle mission to follow. The mission will debut and test new designs incorporated into the Shuttle's external fuel tank and processes that eliminate the likelihood that future Space Shuttle flights could suffer damage similar to Columbia. New cameras and techniques will photograph the

tank during launch and after it is jettisoned from the Shuttle to allow engineers to evaluate the performance of those new designs.

The mission also will debut a variety of new techniques to ensure the health of the Shuttle heat shield can be confirmed in space. New ground and flight camera and sensor systems will observe the Shuttle environment during launch and in orbit. New techniques will be used for in-flight inspection. New methods under development for repair of the Shuttle's heat-shielding Thermal Protection System will be tested. Also, Discovery will deliver a pressurized cargo container full of supplies to the Space Station and a key spare part that Collins and her crew will install during one of the mission's three spacewalks.

Noguchi and Robinson will take those spacewalks. They'll test Shuttle heat shield repair material and techniques, replace one of the Station's control gyroscopes, restore power to another and install a work platform for future in-orbit construction.

Lawrence is in charge of the transfer of supplies and equipment to the Station. She and other crew members will operate the Shuttle and Station robotic arms. The arms are used to assist spacewalks, install equipment and inspect the orbiter's thermal protective tiles.

Thomas will be the primary operator for the Shuttle's robotic arm as it uses a new boom extension to perform an unprecedented inspection of the Shuttle's heat shield. He also will serve as the choreographer from inside the

Shuttle cabin during three spacewalks the STS-114 crew will perform.

Camarda will share Space Shuttle robotic arm duties with Thomas. He also will prepare rendezvous and navigation equipment and help Lawrence transfer supplies to and from the Station. Using both the Station's robotic arm and the Shuttle's robotic arm at times, the mission will involve some of the most complex space robotics work ever performed.

The mission itself goes by many names. Most commonly, it is called STS-114. STS stands for "Space Transportation System" -- an early moniker for the Space Shuttle Program -- and its number refers to the order in which the mission was planned. It also happens to be, in order of flight, the 114th mission in the history of the Space Shuttle Program.

Because of its role in supplying the International Space Station, the mission also is referred to as LF-1, or Logistics Flight 1. Discovery also has a second name; engineers inside NASA often refer to it as OV-103, which stands for Orbiter Vehicle-103.

The top priority of the flight is to inspect all of the Reinforced Carbon-Carbon (RCC) heat protection material on Discovery's wing leading edge panels. Another high priority is sending to the ground for evaluation data gathered during launch by 176 sensors mounted inside the wing panels.

En route to the Station the day after launch, the crew will use what will be a 100-foot-long robotic arm, the 50-foot Shuttle arm tipped with a 50-foot-long Orbiter Boom and Sensor System (OBSS), to inspect critical heat shield areas. The boom is tipped with two types of lasers and a high-resolution television camera. It will be used to inspect key areas of Discovery's wings and nose, the areas that are subjected to the most intense heat during re-entry, for damage.

Another inspection will be performed by the Station's crew as the Shuttle moves in to dock to the complex on the third day of the flight. About 200 yards away from the Station, Collins will fly the Shuttle through a slow backflip, allowing its underside to face the Station for a minute and a half. During that time, the Station crew will snap a precise set of still, digital images using high-magnification lenses to document the heat shield's condition. Soon after, those images will be transmitted to the ground for analysis.

On the fourth day of the mission, more than 2½ years since a Shuttle has delivered supplies to the Station, the crew will use the Station's robotic arm to lift an Italian-built cargo module named Raffaello, technically known as a Multi-Purpose Logistics Module (MPLM), out of the Shuttle cargo bay and attach it to the Station. They then will begin to transfer several tons of supplies and equipment to the Station for use by the Station's Expedition 11 Crew, Commander Sergei Krikalev and Flight Engineer John Phillips. This will be the third trip to the Station for Raffaello, the second of three such cargo carriers to be put into service. Raffaello flew aboard Endeavour on STS-100 and STS-108 in 2001. In addition, Discovery and its crew will transfer water to the Station for use in a variety of applications.

The first spacewalk will take place on the fifth day of the mission. Each of the three spacewalks scheduled for Robinson and Noguchi is planned to be 6 1/2 hours long. The first spacewalk will include a demonstration of techniques for repairing two types of Shuttle heat shield materials: the RCC segments that protect the Shuttle's nose cone and wing edges and the thermal tiles that provide heat protection for the spacecraft's bottom. Another technique for repairing RCC will be tested inside the Shuttle. Two additional heat shield repair techniques under evaluation will be carried aboard Discovery, but not tested on the first mission. During the first spacewalk, the crew also will

make connections that will restore power to a Station gyroscope that has been out of service since a circuit breaker failed in February.

A second spacewalk will take place on the seventh day of the flight and be dedicated to the replacement of one of the Station's four Control Moment Gyroscopes (CMGs). Each spinning almost 10 million times a day, the gyroscopes provide a method of maintaining the Station's orientation in orbit using electrical power instead of rocket thrusters. Noguchi and Robinson will remove from the Station a washing machine-sized gyroscope that experienced a mechanical failure of its spin bearing on June 8, 2002. Mounted inside the Station's central Z1 Truss, the gyroscope will be replaced with a new unit delivered on Discovery in a protective canister called the Mission Peculiar Equipment Support Structure (MPES). With this new gyroscope installed, and the gyroscope repowered on the first spacewalk, all four of the Station's gyroscopes will be restored to operation. Although the Station has operated well with only two functioning gyroscopes, all four will be needed as its assembly resumes and its size increases. Each CMG is four feet in diameter, weighs 620 pounds and consists of a large, flat wheel rotating at a constant speed of 6,600 revolutions per minute.

TIMELINE OVERVIEW

FLIGHT DAY 1:

- Following launch, Discovery's crew sets up the on-board laptop computer network, checks out the Shuttle Remote Manipulator System (SRMS) and conducts Detailed Test Objective (DTO) 850, Water Spray Boiler Cooling with Water/PGME Antifreeze.
- The crew plays back handheld launch video of the External Tank (ET) and loads digital ET photos and data from Discovery's Wing Leading Edge (WLE) sensors into a laptop computer for downlink.
- Overnight, Mission Control will downlink data from the WLE sensors for analysis by engineers looking for sites of potential debris impacts during launch.

FLIGHT DAY 2:

- The Shuttle crew completes SRMS checkout, if necessary, and installs the centerline camera in the Orbiter Docking System.
- The crew grapples and unberths the Orbiter Boom & Sensor System (OBSS) and conducts an SRMS/OBSS survey of Discovery's wing leading edges and nose cap.
- The crew begins a checkout of the rendezvous tools.
- The crew conducts photography of the Orbital Maneuvering System (OMS) pods
- Orbiter Docking System (ODS) is extended.
- The crew performs system checks on the Extravehicular Mobility Unit (EMU) spacesuits and tools in preparation for upcoming spacewalks.
- The crew berths the OBSS.

- The crew surveys Discovery's upper surfaces and the crew cabin using the SRMS.

FLIGHT DAY 3:

- The crew begins the final stage of rendezvous operations as Discovery closes in for docking with the International Space Station.
- Discovery performs the Rendezvous Pitch Maneuver, enabling the Space Station crew to photograph Discovery's thermal protection systems.
- Discovery docks with the Space Station.
- The Shuttle and Station crews open the hatches and shake hands.
- The crews begin transferring cargo from Discovery to the Station.
- The crew uses the Space Station RMS (SSRMS) to grapple the OBSS and hand it off to the SRMS.

FLIGHT DAY 4:

- The crew grapples the Raffaello Multi-Purpose Logistics Module (MPLM) with the SSRMS, unberths the MPLM from Discovery and installs it on the Unity module's Common Berthing Mechanism (CBM).
- The SSRMS ungrapples from the MPLM and begins its walk-off to the Mobile Base System (MBS).
- The crew uses the OBSS to conduct a survey of Discovery's heat-protection tiles.
- The crew activates the MPLM and ingresses.
- The crew configures tools for the first spacewalk and begins Extravehicular Activity (EVA) pre-breathe.
- Crewmembers conduct an in-flight interview.

- The crew performs a checkout of the Simplified Aid for EVA Rescue.
- The hatches between Discovery and the Space Station are closed and Discovery's cabin is depressurized to 10.2 pounds per square inch (psi) in preparation for the first spacewalk, to be done from the Shuttle airlock.

FLIGHT DAY 5:

- Final preparations begin for the first spacewalk.
- The SSRMS walks off the MBS, grappling Destiny.
- The Shuttle crew begins the first spacewalk from the Shuttle airlock.
- Hatches between Discovery and the Space Station are opened. Two crewmembers move to the Station to perform SSRMS EVA support. Transfer activity resumes.
- The spacewalkers perform Shuttle Thermal Protection System Emittance Wash Applicator (EWA) and NOAX (Non-Oxide Adhesive eXperimental) sample repair DTO 848 in Discovery's payload bay.
- The External Stowage Platform-2 (ESP-2) Attachment Device (ESPAD) is unberthed from Discovery and installed onto Quest.
- The GPS antenna is removed and replaced on the S0 Truss.
- The crew uses OBSS to scan damaged reinforced carbon-carbon samples on the DTO pallet.
- The Shuttle and Station hatches are closed, and the spacewalking astronauts ingress Discovery's airlock.
- Shuttle and Station hatches are reopened.

- The Station crew makes preparations for the Control Moment Gyroscope (CMG) removal and replacement.

FLIGHT DAY 6:

- Transfers continue from Discovery to the Space Station.
- Crewmembers participate in two separate in-flight interviews.
- Procedures are reviewed for the second spacewalk and EVA pre-breathe begins.
- Hatches between Discovery and the Space Station are closed and the Shuttle cabin is depressurized to 10.2 psi.

FLIGHT DAY 7:

- The second spacewalk begins.
- Hatches between Discovery and the Station are reopened. Two crewmembers move to the Station to perform EVA SSRMS support, and transfers resume.
- Spacewalkers remove and replace CMG 1, then Mission Control performs a checkout of the new CMG.
- Shuttle and Station hatches are closed and the spacewalkers ingress the Shuttle airlock.
- New Station CMG 1 is started.
- Shuttle and Station hatches are opened.

FLIGHT DAY 8

- Transfers resume between Discovery and the Station.
- Discovery's crew begins its off-duty period.
- The Shuttle crew reviews procedures and begins pre-breathe for tomorrow's third spacewalk from the Shuttle airlock.

- Shuttle and Station hatches are closed. The Shuttle cabin is depressurized to 10.2 psi in preparation for third spacewalk.

FLIGHT DAY 9:

- The third spacewalk of the mission begins.
- Hatches between Discovery and the Station are opened.
- Spacewalkers install an external camera and illuminator on P1 Truss.
- SSMRS grapples and unberths ESP-2 from Discovery's payload bay.
- Two MISSE experiments are retrieved from the Quest airlock, and a new MISSE is installed at the top of the P6 Truss.
- SSRMS delivers ESP-2 to ESPAD, and spacewalkers install.
- Transfers continue between Shuttle and Station.
- SSRMS ungrapples ESP-2 and maneuvers to MPLM.
- Hatches between Discovery and Station are closed, the spacewalkers re-enter the Shuttle airlock and the third EVA ends.
- Hatches between Discovery and the Station are opened.
- SSRMS grapples MPLM for tomorrow's unberth from Unity.

FLIGHT DAY 10:

- The crew egresses and deactivates MPLM.
- MPLM is uninstalled from Unity.
- Rendezvous checkout begins.
- The MPLM is berthed in Discovery's payload bay.
- The SRMS maneuvers the OBSS to handoff position.

- SSRMS grapples the OBSS from the RMS.
- SSRMS berths OBSS in Discovery's payload bay.

FLIGHT DAY 11:

- Discovery and Station crews bid farewell and close their hatches.
- Centerline camera is reinstalled.
- Discovery undocks and separates from the Station.
- Shuttle crew off-duty period begins.

FLIGHT DAY 12:

- Discovery crew performs Flight Control System checkout and begins cabin stowage in preparation for tomorrow's landing.
- Crew performs Reaction Control System hot fire and reviews tomorrow's deorbit timeline.
- KU Band antenna is stowed.

FLIGHT DAY 13:

- Discovery's crew begins deorbit preparations.
- Payload bay door is closed for entry.
- Deorbit burn occurs.
- Landing occurs at Kennedy Space Center.

STS-114 (LF1) Overview Timeline

MET	0/-12	-11	-10	-9	-8	-7	-6	-5	-4	-3	-2	-1	0	1	2	3	4	5	6	7	8	9	10	11	12
STS													ASC	PI	RMS C/O, LAN s/u	Pre-Sleep	Sleep								
ATT													ASC	-ZLV +YVW			OMS	-ZLV -YVW							
												^OMS2				^NC1									
MET	0/12	13	14	15	16	17	18	19	20	21	22	23	1/0	1	2	3	4	5	6	7	8	9	10	11	12
STS	Sleep	FD2	Post Sleep	RMS C/O		Grapple, Unberth	PTV, Rndz tools s/u	Meal	EMU c/o			Pre-Sleep			Sleep										
ATT	-ZLV -YVW		OMS	Bias -ZLV -YVW (Survey)			INTRL (Surv)		Bias -ZLV -YVW (Survey)			RCS	-ZLV -YVW												
												^NC2				^NPC^NC3									
MET	1/12	13	14	15	16	17	18	19	20	21	22	23	2/0	1	2	3	4	5	6	7	8	9	10	11	12
STS	Slip3	Post Sleep	Rndz					Approach, Dock, Leak Cks		Hatch open / safety brief		Boom h/o		Pre-Sleep	Sleep										
ISS	Sleep	Post Sleep	DPC	Rndz					Pitch mnvr P/TV		SSRMS Spt		DPC	Pre-Sleep	Sleep										
ATT	-ZLV -YVW	-ZLV +YVW	Rndz					Bias -XLV -ZVW																	
												NH^		^NC4		^Ti		^Docking							
MET	2/12	13	14	15	16	17	18	19	20	21	22	23	3/0	1	2	3	4	5	6	7	8	9	10	11	12
STS	Slip4	Post Sleep	MPLM Install			Meal	SSRMS w/o	OBSS Survey		EVA Rww	PS	EGRS 10.2	Pre-Sleep	Sleep											
ISS	Sleep	Post Sleep	DPC	EVA tool prep			Meal	MPLM Vest, Act, Ingress			EVA Rww	DPC	Pre-Sleep	Sleep											
ATT	Bias -XLV -ZVW																								
MET	3/12	13	14	15	16	17	18	19	20	21	22	23	4/0	1	2	3	4	5	6	7	8	9	10	11	12
STS	Slip5	Post Sleep	EVA PREP / EMU PURGE			TPS DTO, CMG/ESP Getaheads, GPS Ant (6:30)					Post EVA	Pre-Sleep			Sleep										
ISS	Sleep	Post Sleep	DPC	Transfer								DPC	Pre-Sleep	Sleep											
ATT	Bias -XLV -ZVW																								

MET	4/12	13	14	15	16	17	18	19	20	21	22	23	5/0	1	2	3	4	5	6	7	8	9	10	11	12
STS	FD6 Slp	Post Sleep		EVA tool prep, PWR & Waste dumps				Meal	Transfer, CWC fill		EVA Rww	PS	EGRS 10.2	Pre-Sleep		Sleep									
ISS	Slp	Post Sleep	DPC	Transfer							EVA Rww		DPC	Pre-Sleep		Sleep									
ATT	Bias -XLV -ZV			Water dump				Bias -XLV -ZV																	
MET	5/12	13	14	15	16	17	18	19	20	21	22	23	6/0	1	2	3	4	5	6	7	8	9	10	11	12
STS	FD7 Slp	Post Sleep		EVA PREP / EMU PURGE		CMG R&R (6:30)					Post EVA		Pre-Sleep		Sleep										
ISS	Slp	Post Sleep	DPC	Transfer									DPC	Pre-Sleep		Sleep									
ATT	Bias -XLV -ZV																								
MET	6/12	13	14	15	16	17	18	19	20	21	22	23	7/0	1	2	3	4	5	6	7	8	9	10	11	12
STS	FD8 Slp	Post Sleep		EVA tool prep		Crew Conf	Meal	Off Duty				EVA Rww	PS	EGRS 10.2	Pre-Sleep		Sleep								
ISS	Slp	Post Sleep	DPC	Transfer			Crew Conf	Meal	ECLSS DTO				EVA Rww		DPC	Pre-Sleep		Sleep							
ATT	Bias -XLV -ZV																								
MET	7/12	13	14	15	16	17	18	19	20	21	22	23	8/0	1	2	3	4	5	6	7	8	9	10	11	12
STS	FD9 Slp	Post Sleep		EVA PREP / EMU PURGE		ETVCG/ESP2/MISSE 5 Install (6:00)					Post EVA		Pre-Sleep		Sleep										
ISS	Slp	Post Sleep	DPC	Transfer				CPA Install		Transfer				DPC	Pre-Sleep		Sleep								
ATT	Bias -XLV -ZV																								
MET	8/12	13	14	15	16	17	18	19	20	21	22	23	9/0	1	2	3	4	5	6	7	8	9	10	11	12
STS	FD10 Slp	Post Sleep		Post EVA EMU config				Meal	MPLM Uninstall		Boom h/o		Pre-Sleep		Sleep										
ISS	Slp	Post Sleep	DPC	MPLM Egress, Deact, Vest				Meal	MDDK Xfer						DPC	Pre-Sleep		Sleep							
ATT	Bias -XLV -ZV																								

MET	9/12	13	14	15	16	17	18	19	20	21	22	23	10/0	1	2	3	4	5	6	7	8	9	10	11	12					
STS	FD11 Sleep	Post Sleep		Egress/Undock			Meal		Off Duty				Pre-Sleep		Sleep								PS							
ISS	Sleep	Post Sleep	DPC	Egress/Undock																										
ATT	Bias -XLV -ZVV				Undock/Sep		Bias -ZLV +YVW					-ZLV -XVW																		
^Undock																														
MET	10/12	13	14	15	16	17	18	19	20	21	22	23	11/0	1	2	3	4	5	6	7	8	9	10	11	12					
STS	FD12 Post Sleep	FCS c/o, RCS Hot Fire		Pilot	EVA Stow	Meal	D/O Brief	Cabin Stow		Pre-Sleep		Sleep											PS							
ATT	-ZLV -XVW																													
MET	11/12	13	14	15	16	17	18	19	20	21	22	23	12/0	1	2	3	4	5	6	7	8	9	10	11	12					
STS	FD13 Post Sleep	Deorbit Prep			Entry																									
ATT	-ZLV -xw	IMU	-XSI	Comm		Ent																								

MISSION OBJECTIVES



The STS-114 mission's top priority is to inspect all of the reinforced carbon-carbon heat protection material on Discovery's wing leading edge panels and to downlink data from the 176 wireless impact sensors mounted inside the wing panels for evaluation on the ground. The on-orbit inspections will be carried out using a variety of methods, including umbilical well and hand-held photography of the external tank after it is jettisoned, and an Orbiter Boom Sensor System (OBSS) with lasers.

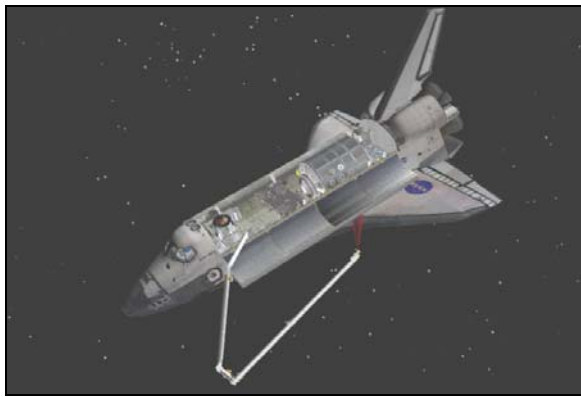

Orbiter Boom Sensor System (OBSS) inspects reinforced carbon-carbon of wing leading edge

Second on the list of priorities is inspecting all of the Shuttle's silicon-based tiles. The third highest priority is to transfer water from the Shuttle to the Station for use by the crew. Other mission objectives include (in order of priority):

- Perform Detailed Test Objective 848 - Orbiter Thermal Protection System Repair Techniques (see "Spacewalk" and "Detailed Supplementary Objectives and Detailed Test Objectives" sections in this kit for more details)

- Transfer critical middeck items from the Space Shuttle to the Space Station
- Perform removal and replacement of the Control Moment Gyro-1 (CMG-1) using the Station arm
- Return the failed CMG-1 to the Lightweight Mission Peculiar Equipment Support Structure Carrier (LMC) using the Station arm
- Berth the Multi-Purpose Logistics Module (MPLM) Raffaello to the Station's Unity module using the Station arm; activate and check out the MPLM
- Transfer critical items from the MPLM to the Station
- Return the MPLM to Discovery's payload bay using the Station arm

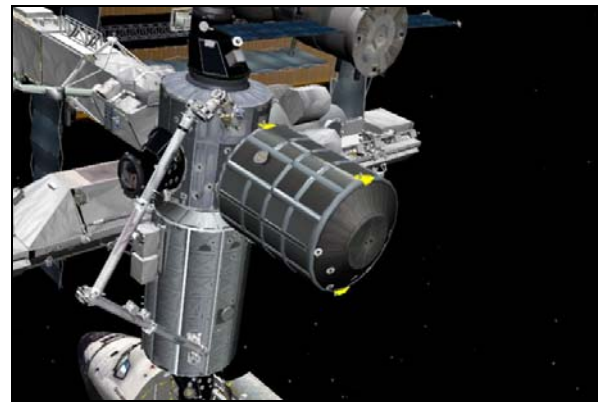

Canadarm2 berths the Raffaello Multi-Purpose Logistics Module (MPLM) to the International Space Station's Unity module

- Install the External Stowage Platform-2 (ESP-2)
- Transfer and install the Human Research Facility-2 rack in the Station's Destiny lab
- Transfer mandatory cargo
- Transfer required cargo

- Remove and replace Hyzod cover on Node 1 nadir hatch window

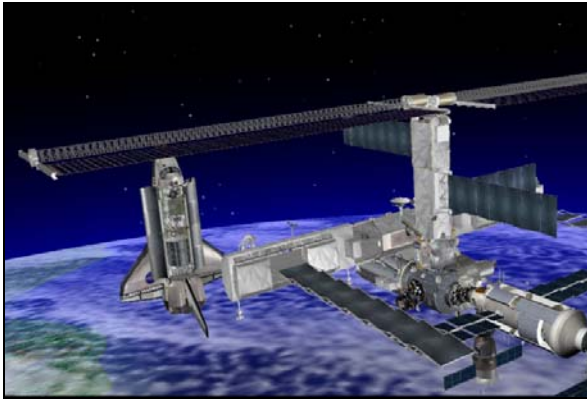

Space Shuttle Discovery prepares to dock with International Space Station

- Remove and replace S0 Global Positioning System (GPS) antenna No. 2
- Install Video Stanchion Support Assembly (VSSA) at the external camera port No. 9 location
- Install the external television camera group No. 3 to the VSSA on camera port No. 9
- Perform Materials International Space Station Experiment (MISSE) Passive Experiment Container (PEC) 5 deployment
- Perform MISSE PEC 1 and 2 retrieval
- Perform orbiter middeck payload operation activities to support powered payload daily status checks
- Perform critical U.S. and Russian daily Space Station payload activities as required to prevent loss of science
- Remove the ESP-2 Flight Releasable Grapple Fixture (FRGF) and return in the Starboard Tool Stowage Assembly (may be deferred if the spacewalk is behind schedule)
- Perform Joint Airlock flush with scrubber/filter
- Transfer remaining cargo
- Perform middeck sortie payload activities
- Reboost the Space Station with the Shuttle to no more than 357 kilometers (192.8 nautical mile) average orbital altitude
- Perform spacewalk get-ahead tasks (see "Spacewalk" section)
- Perform U.S./Russian payload research operations
- Perform Space Station Structural Life Validation and Extension
- Rotate Resupply Stowage Platform to evaluate the redesigned drive pins and verify the ease of on-orbit rack tilting (only if crew time available)
- Perform imagery survey of the Space Station exterior during the Shuttle fly-around after undocking (if propulsive consumables are available)
- Perform Detailed Test Objective 805 operations (see section on "Detailed Supplementary Objectives and Detailed Test Objectives")

LAUNCH AND LANDING

LAUNCH

As with all previous Space Shuttle launches, Discovery on STS-114 will have several modes available that could be used to abort the ascent if needed due to engine failures or other systems problems. Shuttle launch abort philosophy aims toward safe recovery of the flight crew and intact recovery of the orbiter and its payload. Abort modes include:

Abort-To-Orbit (ATO) –

Partial loss of main engine thrust late enough to permit reaching a minimal 105 by 85 nautical mile orbit with orbital maneuvering system engines.

TransAtlantic Abort Landing (TAL) –

Loss of one or more main engines midway through powered flight would force a landing at either Zaragoza, Spain; Moron, Spain; or Istres, France. For launch to proceed, weather conditions must be acceptable at one of these TAL sites.

Return-To-Launch-Site (RTL) –

Early shutdown of one or more engines, and without enough energy to reach Zaragoza, would result in a pitch around and thrust back toward KSC until within gliding distance of the Shuttle Landing Facility. For launch to proceed, weather conditions must be forecast to be acceptable for a possible RTL landing at KSC about 20 minutes after liftoff.



Space Shuttle Discovery launches from Kennedy Space Center on STS-105 on Aug. 10, 2001.

LANDING

The primary landing site for Discovery on STS-114 is the Kennedy Space Center's Shuttle Landing Facility. Alternate landing sites that could be used if needed due to weather conditions or systems failures are at Edwards Air Force Base, California, and White Sands Space Harbor, New Mexico.



Space Shuttle Discovery lands at the Shuttle Landing Facility in Florida on Aug. 22, 2001.

MISSION PROFILE

CREW

Commander:	Eileen Marie Collins
Pilot:	James M. Kelly
Mission Specialist 1:	Soichi Noguchi
Mission Specialist 2:	Stephen K. Robinson
Mission Specialist 3:	Andrew S. W. Thomas
Mission Specialist 4:	Wendy B. Lawrence
Mission Specialist 5:	Charles J. Camarda

LAUNCH

Orbiter:	Discovery (OV-103)
Launch Site:	Kennedy Space Center Launch Pad 39B
Launch Date:	No Earlier Than May 22, 2005
Launch Time:	1:04 p.m. EDT (Preferred In-Plane launch time for 5/22)
Launch Window:	5 Minutes
Altitude:	122 Nautical Miles (140 Statute Miles) Orbital Insertion; 190 NM (218 SM) Rendezvous
Inclination:	51.6 Degrees
Duration:	11 Days 19 Hours 32 Minutes

VEHICLE DATA

Shuttle Liftoff Weight:	4,522,992 pounds
Orbiter/Payload Liftoff Weight:	267,825 pounds
Orbiter/Payload Landing Weight:	226,885 pounds

Software Version: OI-30

Space Shuttle Main Engines:

SSME 1: 2057

SSME 2: 2054

SSME 3: 2056

External Tank:	ET-120
SRB Set:	BI-I124
RSRM Set:	RSRM 90

SHUTTLE ABORTS

Abort Landing Sites

RTLS: Kennedy Space Center Shuttle Landing Facility

TAL: Primary - Zaragoza; Alternates Moron and Istres
AOA: Primary - Kennedy Space Center Shuttle Landing Facility; Alternate White Sands Space Harbor

Landing

Landing Date: No Earlier Than June 3, 2005
Landing Time: 8:36 a.m. EDT
Primary landing Site: Kennedy Space Center Shuttle Landing Facility

PAYLOADS

Control Moment Gyroscope
External Stowage Platform-2
Raffaello Multi-Purpose Logistics Module (including the Human Research Facility-2 rack)

DISCOVERY CREW – STS-114



The STS-114 crew was first named in August 2001 with four Space Shuttle astronauts joined by three International Space Station crewmembers. After the

Columbia accident, a decision was made to rotate Station crews on Russian Soyuz spacecraft rather than on the Shuttle.

Following that decision, the core Shuttle crewmembers – Commander Eileen Collins,

Pilot Jim Kelly and Mission Specialists Stephen Robinson and Soichi Noguchi – were joined by Andrew Thomas, Wendy Lawrence and Charles Camarda in November 2003.

Short biographical sketches of the crew follows with detailed background available at:

<http://www.jsc.nasa.gov/Bios/>



In orange launch and entry suits (from left to right): James M. Kelly, pilot; Andrew S. W. Thomas, mission specialist; Wendy B. Lawrence, mission specialist; Charles J. Camarda, mission specialist; and Eileen M. Collins, commander. Wearing Extravehicular Mobility Units used for spacewalks are (left to right) Stephen K. Robinson and Soichi Noguchi, mission specialists

Commander Eileen Collins is a veteran of three space flights and a second-time Commander who has overall responsibility for the on-orbit execution of the mission, Orbiter systems operations, and flight operations including landing the Orbiter. In addition, she will fly the Shuttle in a procedure called the rendezvous pitch maneuver while Discovery is 600 feet below the Station before docking to enable the ISS crew to photograph the Orbiter's upper surfaces and underbelly thermal protection system. She will dock and undock Discovery from the Station as well.



Commander Eileen Collins

Pilot Jim Kelly is flying for the second time and will be responsible for systems operations and assisting in the rendezvous for docking to the Station. In addition, he is both a Shuttle arm operator and a Station arm operator. As such, he will participate in the Orbiter's thermal protection inspection by helping to maneuver the Shuttle robot arm and its Orbiter Boom Sensor System extension and its suite of cameras and sensors. During the three spacewalks, Kelly will maneuver the EVA crew and hardware with the Station arm. He will also participate in transferring cargo from the Space Shuttle to the Space Station.



Pilot Jim Kelly

Mission Specialist 1 (MS1) is Japan Aerospace Exploration Agency (JAXA) Astronaut Soichi Noguchi, who will make his first venture into space. His main objective is to lead and perform three Extravehicular Activities (EVAs), or spacewalks, as EV1 along with his spacewalking colleague, Stephen Robinson. Testing will include new techniques for repairing potential damage to the Orbiter's thermal protection system. He will also replace one of the large ISS gyroscopes that control the orientation of the Station and will help install and activate an External Stowage Platform (ESP-2) for the housing of spare parts for the Station. Noguchi will sit on the flight deck for launch and the middeck for entry.



Soichi Noguchi

Mission Specialist 2 (MS2) is Astronaut Stephen Robinson, a veteran of two space

flights who will serve as the Flight Engineer on STS-114, adding a second set of eyes on Orbiter systems for the Commander and the Pilot on the flight deck during launch and landing. In addition to these duties, he also serves as a member of the spacewalk team. As EV2, Robinson will perform three spacewalks along with Soichi Noguchi, during which they will test Shuttle thermal protection system repair techniques, replace one of the large ISS orientation gyroscopes, and install and activate an External Stowage Platform on the Station's Airlock.



Stephen Robinson

Mission Specialist 3 (MS3) is Astronaut Andrew Thomas, a veteran of three space flights. He will be the lead Shuttle robotics officer for the inspection of the Orbiter's thermal protection system using a new boom extension outfitted with sensors and cameras. He will also serve as the Intravehicular Activity (IV) crewmember helping to suit up and choreograph spacewalkers Soichi Noguchi and Stephen Robinson during their three spacewalks. Thomas will move the Shuttle's 50-foot-long robot arm and lock it onto the Orbiter Boom Sensor System (OBSS). Thomas, Pilot Jim Kelly, and Mission Specialist Charlie Camarda will maneuver the boom along the leading edges of the wings and nose cap to collect detailed imagery with lasers and a video camera. Thomas will also be on the middeck for launch and the flight deck for entry and landing.



Andrew Thomas

Mission Specialist 4 (MS4) is Astronaut Wendy Lawrence, a veteran of three space flights, who will serve as the lead for transferring supplies from the Shuttle's cargo module to the Station. She will also perform ISS robotics duty for thermal protection inspection and the spacewalks, and assist with the rendezvous.



Wendy Lawrence

As a Station arm operator, she will maneuver her crewmembers and hardware during the three spacewalks. During the rendezvous,

docking and undocking, she will manage computers, lasers, cameras, and the Orbiter Docking System. Lawrence will be seated in the middeck for launch and landing.

Mission Specialist 5 (MS5) is Astronaut Charles Camarda, who will make his first flight into space. His duties include Shuttle robotics, assisting in the external inspection of the Orbiter's thermal protection system, photography and television support, and computer operations. Camarda will also be heavily involved in logistics and transfer operations from the Shuttle to the Station. During the Orbiter's thermal inspection using the new Orbiter Boom Sensor extension, he will operate the robot arm, lasers, cameras, and computers, and will downlink all of the data to the Mission Control Center (MCC) in Houston. During the rendezvous and undocking, he will help manage the lasers, cameras, computers, and the Orbiter Docking System. Camarda will be seated in the Shuttle's middeck for launch and landing.



Charles Camarda

KEY MISSION PERSONNEL

KEY CONSOLE POSITIONS FOR STS-114

	FLIGHT DIRECTOR	CAPCOM	PAO
Ascent	Leroy Cain	Ken Ham Rick Sturckow (Wx)	James Hartsfield
Orbit 1	Paul Hill (Lead)	Steve Frick	Rob Navias
Orbit 2	Tony Ceccacci	Julie Payette	Kelly Humphries (Lead)
Planning	Cathy Koerner	Shannon Lucid	Kylie Clem
Entry	Leroy Cain	Ken Ham Rick Sturckow (Wx)	James Hartsfield
ISS Orbit 1	Bryan Lunney	Charlie Hobaugh	n/a
ISS Orbit 2	Mark Ferring (Lead)	Mike Massimino	n/a
ISS Orbit 3	Joel Montalbano	Steve Swanson	n/a
Mission Control Korolev, Russia	John McCullough Ginger Kerrick Mark Kirasich (backup)	n/a	n/a

KSC Launch Commentator – George Diller
 KSC Launch Director – Mike Leinbach
 NASA Test Director – Jeff Spaulding

MISSION AND PROGRAM MANAGERS

Space Shuttle Program Office (NASA)

Manager, Space Shuttle Program - Bill Parsons
 Deputy Manager, Space Shuttle Program - Wayne Hale
 Manager, Shuttle Safety and Mission Assurance - Terry Wilcutt
 Manager, Shuttle Flight Operations and Integration - John Shannon
 Manager, Shuttle Systems Engineering and Integration - John Muratore
 Manager, Shuttle Management Integration and Planning - John Casper
 Manager, Shuttle Strategic Planning Office - Lee Norbraten
 Manager, Orbiter Projects Office - Steve Poulos, Jr.
 Deputy Manager, Orbiter Projects Office - Ed Mango

Kennedy Space Center (KSC)

Deputy Manager, Space Shuttle Program – Denny Kross

Manager, Launch Integration – Gregory C. Johnson

Director of Shuttle Processing – Mike Wetmore

Launch Director – Mike Leinbach

KSC Director, S&MA – Larry Crawford

Discovery Vehicle Manager – Stephanie Stilson

STS-114 Payload Manager – Scott Higginbotham

Chief Engineer – Charlie Abner

STS-114 Shuttle Test Director – Jeff Spaulding

United Space Alliance (USA)

United Space Alliance Vice President and Program Manager – Howard DeCastro

USA Vice President and Deputy Program Manager, Houston Operations – Loren Shriver

USA Vice President and Deputy Program Manager, Florida Operations – Bill Pickavance

USA Space Operations Management

United Space Alliance President and Chief Executive Officer – Mike McCulley

United Space Alliance Executive Vice President and Chief Operating Officer – Brewster Shaw

RENDEZVOUS AND DOCKING



Discovery's approach to the International Space Station during the STS-114 rendezvous and docking process will include an unprecedented maneuver -- a back-flip pirouette -- enabling

Station residents to take digital photographs of the Shuttle's thermal protection system.

With Discovery's Commander Eileen Collins at the controls, Discovery will perform the 360-degree pitch-around with the orbiter about 600 feet below the Station. The flip will take about 9 minutes to complete, offering Expedition 11 Commander Sergei Krikalev and Flight Engineer John Phillips about 93 seconds of photography time to capture images of Discovery.

The images recorded during the so-called Rendezvous Pitch Maneuver (RPM) are among several new inspection procedures designed to detect and determine the extent of any damage the orbiter's protective tiles and reinforced carbon-carbon surfaces might have sustained.

The sequence of events that brings Discovery to its docking with the Station begins with the precisely timed launch of the orbiter, placing the Shuttle on the correct trajectory and course for its two-day chase to arrive at the Station. During the first two days of the mission, periodic engine firings will gradually bring Discovery to a point about 9½ statute miles behind the Station, the starting point for a final approach.

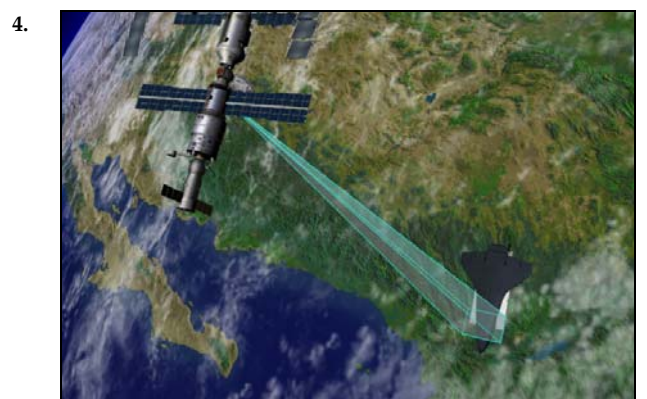
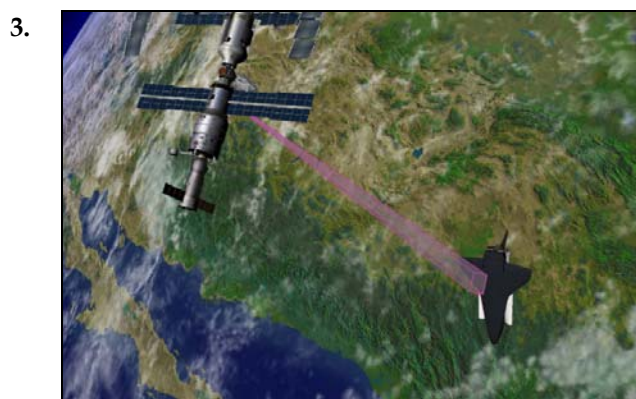
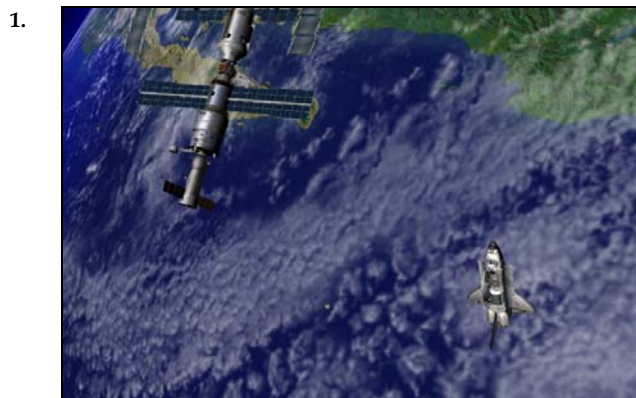

1. Discovery begins the RPM at a distance of 600 feet from the ISS
2. Discovery presents its heat-resistant tiles for photographic inspection by the ISS crew
3. An 800 mm lens provides more detailed close-ups of sensitive tile areas around Discovery's wheel well doors
4. Space Station crewmembers use a digital camera and 400 mm lens to photograph the condition of Discovery's tiles

About 2½ hours before the scheduled docking time on Flight Day 3, Discovery will reach that point, about 50,000 feet behind the ISS. There, Discovery's jets will be fired in a Terminal Initiation (TI) burn to begin the final phase of the rendezvous. Discovery will close the final miles to the Station during the next orbit.

As Discovery closes in, the Shuttle's rendezvous radar system will begin tracking the Station and providing range and closing rate information to the crew. During the final approach, Discovery will execute several small mid-course corrections at regular intervals with its steering jets. That will place Discovery at a point about 1,000 feet directly below the Station at which time Collins will take over the manual flying of the Shuttle up the R-Bar, or radial vector toward the complex, the imaginary line drawn between the Station and the Earth.

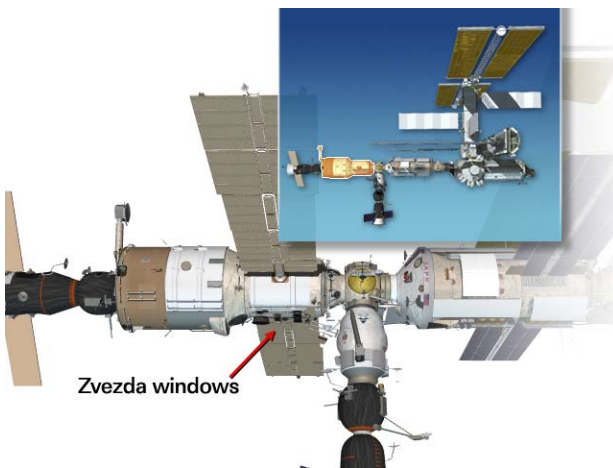

Station crewmembers will use Earth-facing windows in the Zvezda Service Module to take photographs during the Rendezvous Pitch Maneuver

She will slow Discovery's approach and fly to a point about 600 feet directly below the Station for a period of station-keeping to wait for the proper lighting conditions. The rendezvous is designed so that there will be as little glare as possible on the surfaces of the Shuttle.

Rendezvous Approach Profile

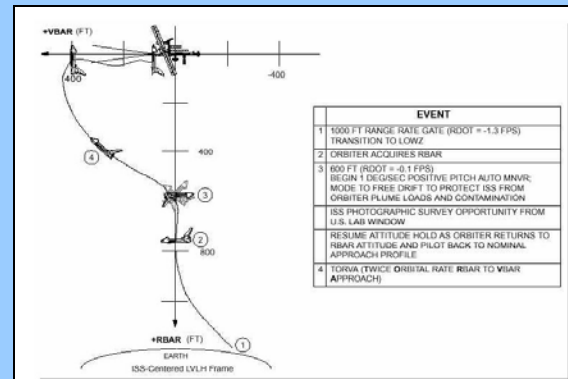

Space Shuttle Rendezvous Maneuvers

OMS-1 (Orbit insertion) - Rarely used ascent abort burn.

OMS-2 (Orbit insertion) - Typically used to circularize the initial orbit following ascent, completing orbital insertion. For ground-up rendezvous flights, also considered a rendezvous phasing burn.

NC (Rendezvous phasing) - Performed to hit a range relative to the target at a future time.

NH (Rendezvous height adjust) - Performed to hit a delta-height relative to the target at a future time.

NPC (Rendezvous plane change) - Performed to remove planar errors relative to the target at a future time.

NCC (Rendezvous corrective combination) - First on-board targeted burn in the rendezvous sequence. Using star tracker data, it is performed to remove phasing and height errors relative to the target at Ti.

Ti (Rendezvous terminal intercept) - Second on-board targeted burn in the rendezvous sequence. Using primarily rendezvous radar data, it places the orbiter on a trajectory to intercept the target in one orbit.

MC-1, MC-2, MC-3, MC-4 (Rendezvous midcourse burns) - These on-board targeted burns use star tracker and rendezvous radar data to correct the post-Ti trajectory in preparation for the final, manual proximity operations phase.

On a verbal cue from Pilot Jim Kelly to alert the Station crew, Collins will command Discovery to begin a nose-forward, three-quarter-of-a-degree-per-second back flip. As the Shuttle passes 145 degrees into the maneuver, Kelly will tell Krikalev and Phillips to begin their photography of Discovery. The Station residents will shoot from the Shuttle's tail to its nose to avoid any residual glare. The photography will be performed out of windows 6 and 7 in the Zvezda Service Module with Kodak DCS 760 digital cameras and 400mm and 800mm lenses delivered on a Russian Progress cargo ship to the Station in March.

The digital camera with the 400mm lens will be used to capture imagery of the upper surfaces of the Shuttle with a two-inch resolution. The other camera with the 800mm lens will be used to concentrate on Discovery's belly, capturing pictures of the nose landing gear door seals, the main landing gear door seals and the elevon cove with one-inch analytical resolution. There should be enough time for two sets of pictures. After docking is complete, the photos will be downlinked through the Station's Ku-band communications system for analysis by systems engineers and mission managers.

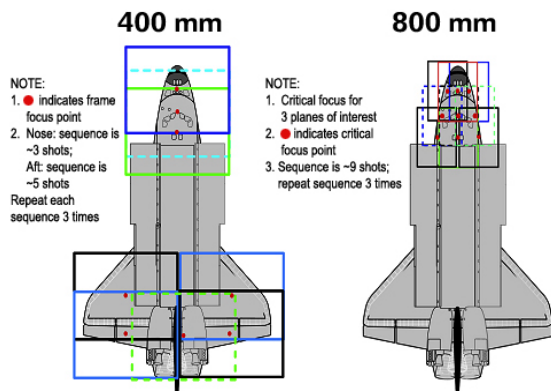

When Discovery is 215 degrees into the maneuver, Kelly will direct the crew to stop its photography. Discovery will then complete its rotation, returning to an orientation with its payload bay facing the Station.

Mapping sequences will provide thorough coverage of Discovery's thermal protection system

Collins will then move Discovery to a point about 400 feet in front of the Station along the direction of travel for both spacecraft, known as the velocity vector, or V-Bar. Kelly will provide Collins with navigation information as she slowly inches the Shuttle toward the docking port at the forward end of the Station's Destiny Laboratory. Mission Specialists Wendy Lawrence, Steve Robinson and Charlie Camarda also will play key roles in the rendezvous. Robinson will operate laptop computers processing the navigational data, while Lawrence and Camarda share roles in operating the laser range systems and Discovery's docking mechanism.

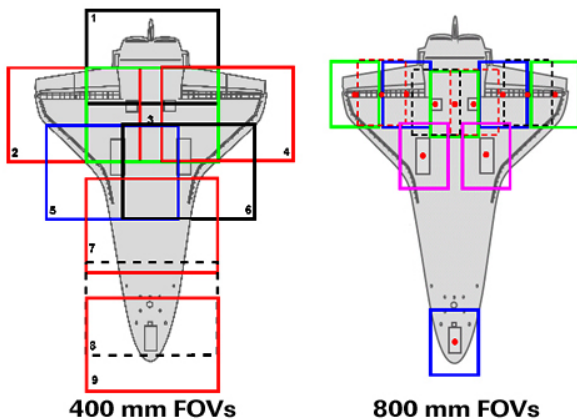

Using a view from a camera mounted in the center of Discovery's docking mechanism as a key alignment aid, Collins will precisely center the docking ports of the two spacecraft. She will fly to a point where the docking mechanisms are 30 feet apart, and pause to check the alignment.

For Discovery's docking, Collins will maintain the Shuttle's speed relative to the Station at about one-tenth of a foot per second (while both Discovery and the Station are traveling at about

17,500 mph), and keep the docking mechanisms aligned to within a tolerance of three inches. When Discovery makes contact with the Station, preliminary latches will automatically attach the two spacecraft. Immediately after Discovery docks, the Shuttle's steering jets will be deactivated to reduce the forces acting at the docking interface. Shock absorber-like springs in the docking mechanism will dampen any relative motion between the Shuttle and the Station.

Once that motion between the spacecraft has been stopped, Camarda will secure the docking mechanism, sending commands for Discovery's docking ring to retract and to close a final set of latches between the two vehicles.

UNDOCKING, SEPARATION AND DEPARTURE

Once Discovery is ready to undock, Camarda will send a command to release the docking mechanism. At initial separation of the spacecraft, springs in the docking mechanism will push the Shuttle away from the Station. Discovery's steering jets will be shut off to avoid any inadvertent firings during the initial separation.

Once Discovery is about two feet from the Station, with the docking devices clear of one another, Kelly will turn the steering jets back on and fire them to very slowly move away. From the aft flight deck, Kelly will manually control Discovery within a tight corridor as the orbiter separates from the Space Station, essentially the reverse of the task performed by Collins just before Discovery docked.

Discovery will continue away to a distance of about 450 feet, where Kelly will initiate a maneuver to fly the Shuttle directly above the Station. At that point, he will fire Discovery's jets to depart the vicinity of the Station for the final time. A full fly-around of the Station, as has been the case on previous Shuttle missions to the Station, likely will not occur due to timeline constraints.

SPACEWALKS



The STS-114 and Expedition 11 crews will work together to accomplish three spacewalks, also known as Extravehicular Activities or EVAs, that focus on Space Station assembly and repair tasks. One spacewalk will include tests of two Shuttle thermal protection system repair methods.

Each of the spacewalks by Soichi Noguchi and Steve Robinson will last approximately 6 hours, 30 minutes. They will be conducted from the Space Shuttle Discovery's airlock, thus becoming the 26th, 27th and 28th Shuttle-based EVAs in support of Space Station assembly. Assuming a May-June launch date, once the STS-114 work is done there will have been a total of 61 Space Station assembly spacewalks.

These will be the first spacewalks for both astronauts. Noguchi will be designated EV1, and will wear the spacesuit marked by red stripes on its legs. Robinson will be designated EV2, and will wear a spacesuit identifiable by white stripes.

Since all three EVAs will be carried out from the Shuttle airlock, Discovery's crew will close the hatches to the Station the night before each EVA and lower the Shuttle's cabin pressure from 14.7 psi to 10.2 psi to help purge nitrogen from the bloodstreams of the spacewalkers. About the same time, Noguchi and Robinson will don masks and pre-breathe pure oxygen for 1 hour to begin the nitrogen purge and protect against "the bends." Noguchi and Robinson also will perform final configuration of the tools and a new digital camera they will use on the next day's spacewalk.

The next day will begin with the start of final EVA preparations when the spacewalkers don their Extravehicular Mobility Unit (EMU)

spacesuits. They will complete the nitrogen purge and pre-breathe pure oxygen in the spacesuits for 75 minutes prior to depressurizing the airlock. After the spacewalkers have exited and closed the hatch behind them, the Shuttle crew will repressurize Discovery and open the hatch to the Station so that the two crews can work together to support their colleagues outside.



STS-114 Mission Specialists Soichi Noguchi (left) and Stephen Robinson look at tools from the Tool Stowage Assembly.

EVA 1

The first spacewalk will take place on Flight Day 5 of the mission. The jobs at hand will be trials of two thermal protection system repair methods, replacement of a GPS antenna, and get-ahead tasks for the Space Station assembly spacewalks on Flight Days 7 and 9.

After exiting Discovery's airlock, Noguchi and Robinson will do their initial setup for the spacewalk. This setup period will include a trip to the Space Station's Quest airlock on the Station's robotic arm for Noguchi to open the hatch and provide an emergency entrance point. The crew lock portion of Quest will have been depressurized by the Expedition 11 crew the night before. Quest's outer hatch will remain open until all three EVAs are completed.

Noguchi will close a thermal cover over the open hatch before returning to Discovery's payload bay to begin the thermal protection repair tests, known as Detailed Test Objective 848 (DTO 848).

For DTO 848, the two spacewalkers will assist one another side-by-side in Discovery's cargo bay at a pallet carrying a variety of damaged Shuttle tiles and reinforced carbon-carbon (RCC) samples. Noguchi and Robinson will have half an hour each to perform their DTO tasks, with 25 additional minutes allocated for cleanup at the tests.

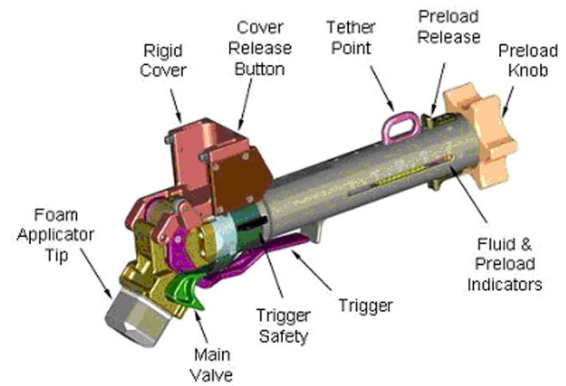

Emittance Wash Applicator



DTO 848 Pallet Configuration

Noguchi will work on tile repair, demonstrating the use of an Emittance Wash Applicator (EWA) and associated tools. The EWA is a dauber-like applicator, used to apply the sticky, caulk-like mixture of fine-grit silicon carbide (SiC) granules and room temperature vulcanizing (RTV) material to exposed tile substrate. Other tools used with this repair technique include foam brushes to cover areas that the larger EWA applicator cannot, and wipes to remove excess material from spacesuits, gloves or tools. His part of the DTO will be considered fully successful if one 4-by-4-inch area of exposed substrate is covered, but additional areas for repair are available if time allows.

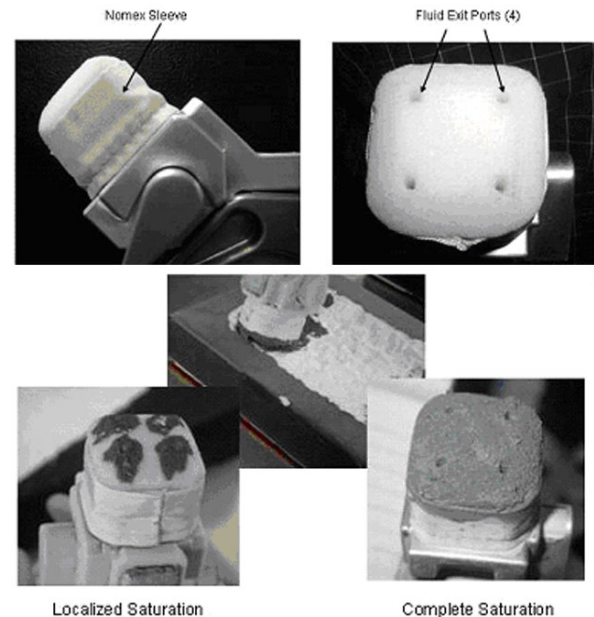

Emittance Wash Applicator dispenses a mixture of fine-grit silicon carbide (SiC) granules and room temperature vulcanizing (RTV) material

In this application, an emittance wash would be used to repair shallow tile damage. The silicon tiles used in the Shuttle's thermal protection system both reject heat and insulate. The white silicon substrate provides insulation, while the black reaction-cured glass (RCG) coating rejects heat. The ability of a material to reject heat is measured in terms of its "emissivity." The RCG coating on tiles has a high emissivity value, while

the white substrate has a lower emissivity value, especially as temperatures rise. The science behind the emittance wash repair involves replacing a damaged tile's coating to restore its ability to reject the high temperatures of atmospheric entry. The emittance wash wicks into the tile substrate, providing an adhesive bond, and a high emissivity, or heat rejection value. For small, shallow areas of damage, replacing the RCG coating with the emittance wash will restore enough heat rejection capability for safe entry.

NOAX (short for Non-Oxide Adhesive eXperimental). Using one of two caulk guns in the crack repair kit, Robinson will dispense the material onto one of two pallets, similar to those used for plastering. He will then use one of two scrapers, similar to putty knives, to work the crack repair material into a pre-damaged RCC sample mounted in the DTO pallet. There are four cracks and two gouges on the RCC sample, and his portion of the DTO will be deemed successful if one crack and one gouge are repaired.

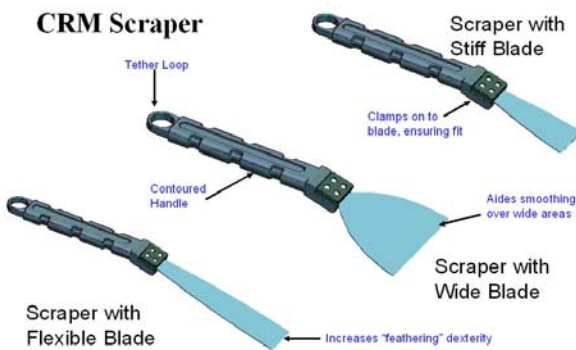
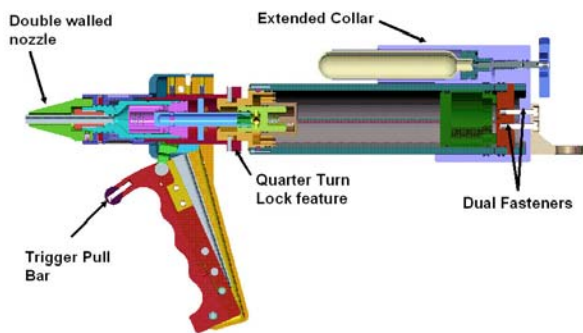

A caulk gun and scrapers will be used to dispense a Non-Oxide Adhesive Experimental (NOAX) repair material into a simulated reinforced carbon-carbon crack

Afterward, Robinson will work with the RCC crack repair technique. He will use a space-hardened caulk gun to dispense a pre-ceramic polymer sealant impregnated with carbon-silicon carbide powder, together known as

NASA materials experts have estimated that cracks or coating damage as small as 2 inches long and .02 of an inch wide in some locations on the Shuttle's wing leading edge could result in catastrophic damage to that wing. The crack filling method is designed to fix the type of damage most likely to be caused by small pieces of foam coming off the redesigned external tank. NOAX can be used at any RCC location, and does not require any physical modification of the RCC before affecting a repair. It is expected to repair cracks or coating losses up to four inches long, but cannot be used to repair holes. While NOAX initially was thought to need a heater to prepare the RCC surface for application and post-application curing, recent tests on the ground have shown promising results that heating the damaged area and the material may not be required. No heaters will be used in the STS-114 tests.

After the DTO 848 tasks are complete, the spacewalkers will work to clean up the work area around the DTO pallet before moving on to their assembly get-ahead work. The lid to the sample box will be left open until the end of the EVA to allow the OBSS sensors to scan the damaged samples in the box.

Removing the External Stowage Platform-2 (ESP-2) Attachment Device (ESPAD) from its Lightweight Multi-Purpose External Support Structure (MPRESS) and installing it on the side

of the Space Station airlock will be the first of those get-ahead tasks. ESPAD is a two-part mechanism, with one part containing the active ESPAD claw, which will provide a temporary structural connection for the ESP-2 when it is first installed. The other half is passive and will remain connected to ESP-2, eventually being grabbed by the claw and then firmly bolted to the active member. They'll be assisted by Jim Kelly and Wendy Lawrence inside the Space Station, operating the Station's robotic arm, and by Andy Thomas inside the Shuttle, who will relay information and instructions from Mission Control.

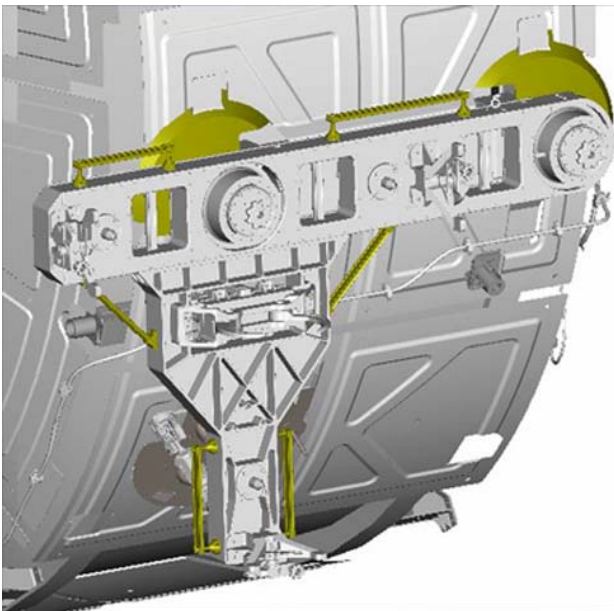

The active half of the External Stowage Platform Attachment Device (ESPAD) installed on the Quest Airlock Module

Robinson's first job will be to install an Articulating Portable Foot Restraint (APFR) into the Latching End Effector (LEE) of the Station's 80-foot-long robotic arm. As a free-floater still, he will verify that the ESPAD claw is open. He will move a pivoting strut out of the way so that he can remove the first of three bolts which hold the active ESPAD in place for launch. He'll return the strut to its original position, and then use a Pistol Grip Tool

(PGT), which is a portable drill modified for use in space, to release mounting locks for the Enhanced Universal Truss Attachment System (EUTAS) that will be used to attach the active ESPAD member to the airlock structure. The mounting locks are installed pre-flight to prevent vibrations from damaging the EUTAS mechanism. The EUTAS uses two knuckled hand-tightening knobs; both can gimble and one can slide to ensure good alignment with the structural members to which they'll be attached.

Once the EUTAS locks are released, he will step into the foot restraint on the end of the Station's robotic arm and use the PGT to loosen the last two ESPAD launch bolts. After separating the active and passive members, the Station arm will be commanded to move Robinson and the ESPAD from the cargo bay to the Quest airlock trunnions and soft dock the ESPAD with Noguchi available for guidance. Robinson will hand-tighten the two EUTAS bolts and verify they are tightened well enough to temporarily hold it in place. Then, he'll use the PGT to finish tightening the bolts and engage their locking mechanisms. Noguchi will deploy the strut and attach it to a fitting on the Quest airlock. At this point, the ESPAD will be ready to structurally accept the ESP-2 on the third spacewalk of the mission.

During this same period, Noguchi's first job will be to pre-route the 20-foot-long primary cable that will connect the ESPAD to power connections on the end cone of the Unity connecting module. First, he'll collect the primary and secondary ESP-2 cables from their launch stowage location in the cargo bay and move hand-over-hand via handrails to the junction of the Unity module and the Station's truss structure near the Destiny module. At the Crew Equipment Translation Aid (CETA) spur, which bridges the gap between Unity and the truss, he will temporarily stow the secondary cable and move to the Unity end cone adjacent to Destiny's end cone with the primary cable.

He'll connect one end of the primary cable to a jack on Unity and stow the rest of the cable on a handrail for later attachment on EVA3.

Next, Noguchi will move back to the Quest airlock, open the thermal cover, and retrieve an Orbital Replacement Unit (ORU) bag containing a Global Positioning System (GPS) antenna and another bag containing Control Moment Gyroscope (CMG) get-ahead equipment and stow them at the Station toolbox on the side of the airlock. With this complete, he'll move to the ESPAD installation location to help Robinson.



A Global Positioning System (GPS) antenna (above) and its location on the International Space Station truss (below)

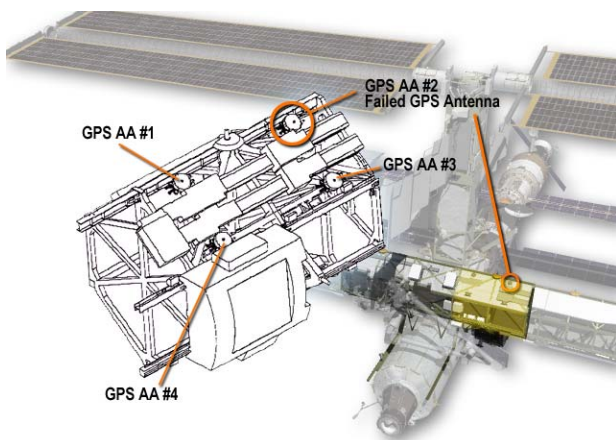

Once the ESPAD is installed, Noguchi will remove a broken GPS antenna that faces space on the port side of the S0 truss. He'll move hand-over-hand to the worksite after collecting the ORU bag containing the replacement antenna. Once at the worksite, he will remove some wire ties that were installed on STS-110 in April 2002 to corral some Multi-Layer Insulation (MLI) that had been interfering with the antenna, and move the MLI out of the way. He'll detach two power and data connectors, use a PGT to release four bolts and lift the failed antenna out of its bay and stow it on a handrail. He'll pull the new antenna out of the ORU bag, soft dock it where the old antenna had been and use the PGT to drive three bolts and secure the antenna. Then, he'll attach the two power and data cables, reinstall the MLI and tie it down out of the way using the wire ties. Last, Noguchi will take the ORU bag with the failed GPS antenna to the CETA cart on the space-facing side off the truss and temporarily stow it there.

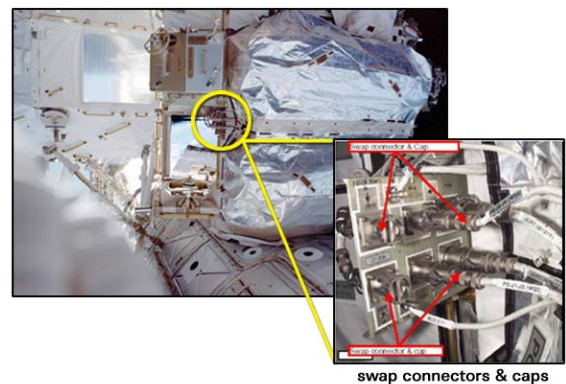

Swapping a cable from one jack to another on a Z1 truss patch panel will allow spacewalkers to reroute power to a Control Moment Gyroscope

At the same time, Robinson will retrieve tools that will be used in the CMG-1 replacement EVA on Flight Day 7 and take them up to the Z1 section of the truss, on the space-facing side of the Unity module. He'll first perform a patch panel swap of an electrical connector that will restore power to CMG-2 which has been inactive since March when a Remote Power Control Module (RPCM) failed. He'll install a temporary handrail strap and fold down a lighting stanchion, tethering it to a handrail to get it out of the way so that he and Noguchi will be able to remove the failed gyroscope and install a replacement.

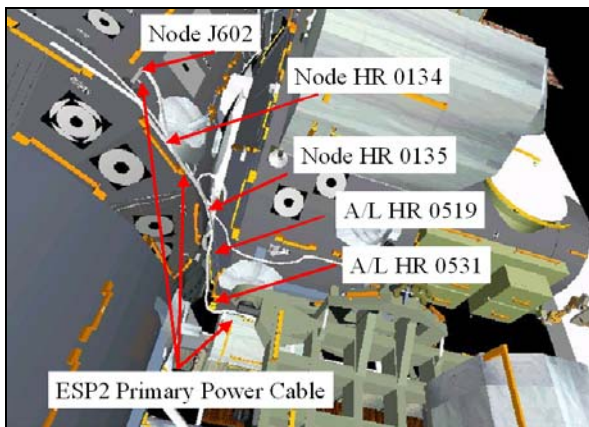







Routing map for the primary power cable to External Storage Platform-2

The last job of the EVA will be to route the 50-foot-long secondary cable for ESP-2, a task that will require both spacewalkers. While Noguchi repositions the CETA cart on top of the truss, Robinson will retrieve the cable from its temporary storage location on the CETA spur and move over to S0 truss Bay 3. Noguchi will push his head and torso into Bay 3, and Robinson will feed the split end of the cable to him. Inside the truss, Noguchi will detach one connector, mate it to one of the the secondary cable connectors, and mate the other connector to its jack. Robinson then will position the secondary cable along several struts and handrails and temporarily position the other end on a handrail near the ESP-2 installation location.

The two then will collect all of their tools and clean up the payload bay before returning to the Shuttle's airlock. Meanwhile, the rest of the shuttle crew will return to Discovery and close the hatches to station to allow the spacewalkers to depressurize the airlock from the outside and open the hatch. They will then reenter the shuttle's airlock with their tools, completing the EVA when the hatch is closed and repressurization begins.

TPS Repair Assets and DTO Plan

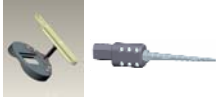
TPS Breakdown	Type of Repair	Purpose	Manifested Tools	Example Picture or Illustration	Quantity	Planned STS-114 DTO Activity?	Planned STS-121 DTO Activity?
Tile Repair	Emittance Wash Repair (and Ablator Repair Primer)	Repair: "shallow gouges", coating damage (Primer: prime damage surface prior to Ablator Repair)	Emittance Wash Applicator (EWA), w/ SiC and RTV-511 (major component of STA-54 "PartA" only)		3, temperature dependent coverage, each unit with ~100 sq. in. (cold) to ~300 sq. in. (ambient)	Yes - EVA, sample box in PLB	No
	Ablator Repair	"Deep gouges", missing tiles	Cure-In-Place-Ablator Applicator (CIPAA), w/ curing repair material, STA-54 ("PartA" and "PartB")		2, each unit with 600 cubic in. usable volume	No	Yes - TBD EVA dispense
			Supporting Hand Tools/Hardware		STS-114: 1set STS-121: 1set, plus some additional spares	No	Yes - TBD to support EVA dispense
	Overlay Repair	Cover for any tile damage	Overlay and supporting equipment		1, (12 in. by 25 in.)	No	No
RCC Repair	Crack Repair	Spalled coating, gouges, cracks, possibly small holes	Crack Repair Gun loaded w/ Crack Repair Material (NOAX 3124D)		STS-114: 3 manual guns (5 oz each); STS-121: 3 pneumatic guns (15 cubic in. each)	Yes - EVA, sample box in PLB	Yes - EVA, sample box in PLB
			Supporting Hand Tools		2 sets, 1 transfer bag	Yes - EVA, sample box in PLB	Yes - EVA, sample box in PLB
	Plug Repair	Larger holes in RCC or "bruised" RCC	Plug coverplates and attachment mechanisms (assembled on-orbit); current plan is to use NOAX 3124D as sealant		STS-114: 13 Plug Coverplates and 4 attachment mechanisms, plus 1 assembled Plug for IVA demo; STS-121: 19 Coverplates and 4 attach mech *Note: better coverage for 121 than 114	Yes - IVA only	Yes - EVA, sample box in PLB
			Supporting Hand Tools		2 sets	Yes - IVA only	Yes - EVA, sample box in PLB

EVA 2

The sole objective of EVA 2 on Flight Day 7 will be the removal and replacement of a failed Control Moment Gyroscope from the Station's Z1 truss. The old CMG failed in June 2002; since then, the Station has used the remaining three CMGs to maintain and adjust the Station's attitude, or orientation, relative to the Earth. At this stage of the assembly sequence, two CMGs are sufficient to control the Station's attitude. The third functioning CMG provides the necessary amount of redundancy, or backup. However, later in the assembly sequence, the Station will become less symmetrical and a minimum of three CMGs will be needed to maintain attitude. So, four healthy gyroscopes will be needed to control the Station's orientation relative to the Earth and offer a backup if another gyroscope were to fail.

Each gyroscope weighs 660 pounds and is about the size of a washing machine. Each has a reaction wheel that spins at a constant speed of 6,600 revolutions per minute. Flight controllers on the ground can use guidance and navigation software to reposition the direction of the gyros' spin axes. Repositioning these axes causes the CMGs to generate torque. This torque is transferred to the Station's structure, counteracting the gravitational and drag forces to maintain attitude or to induce changes to the Station's orientation.

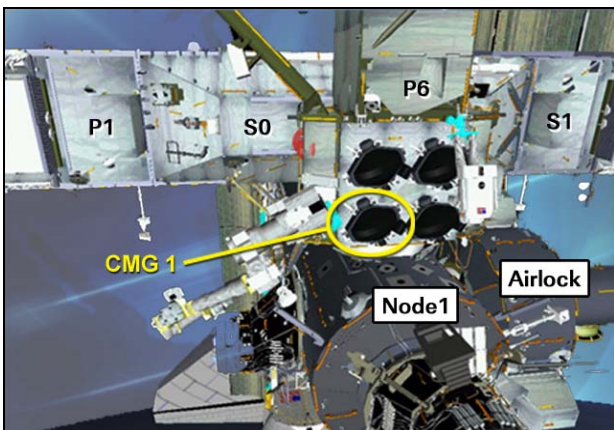

Location of four CMGs are located on the International Space Station's Z1 truss

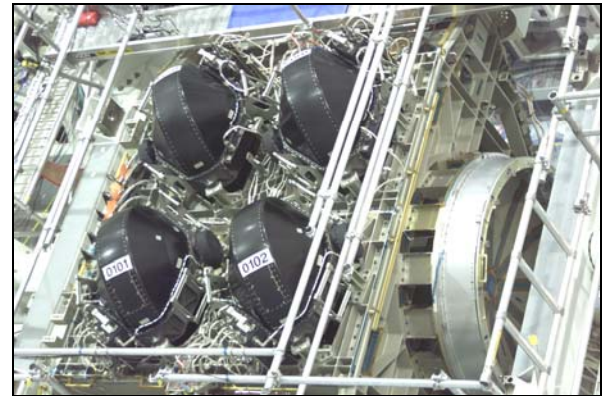

Close-up of CMGs

After exiting the Shuttle airlock, Noguchi and Robinson will make sure their spacesuits and tools are in order and work their way hand-over-hand to the Z1 truss. Noguchi will step into an APFR on the Space Station's robotic arm, which again will be controlled by Kelly and Lawrence. The pair will work together to peel back and secure the multilayer insulation thermal shroud covering CMG-1. After receiving confirmation from Andy Thomas inside the Shuttle and Mission Control, Noguchi will disconnect four power and data cables and tie them out of the way. Next they will loosen the bolts holding the CMG in its support structure; Noguchi will loosen four bolts and Robinson two bolts using PGTs. When all six are loosened, Robinson will wiggle the CMG to make sure it is not binding. Each spacewalker then will remove two launch shims designed to provide a snug fit for the CMG in its support structure. Noguchi will remove four captive bolts and Robinson two, then lift the CMG out of its cradle. Robinson will use his helmet-mounted video camera to send inspection views of the cavity to Mission Control for evaluation.

Kelly and Lawrence will use Canadarm2 to swing Noguchi and the failed CMG back to Discovery's payload bay and the Lightweight Mission Peculiar Equipment Support Structure Carrier (LMC). While Noguchi is in transit, Robinson will move back to the cargo bay and

position two “ball stacks,” which are temporary holding arms, to the CMG carrier. When Noguchi arrives with the old CMG, the pair will secure it to one of these ball stacks.

After the failed CMG is temporarily secured, Noguchi and Robinson will loosen six bolts, remove four shims and six bolts, then lift the new CMG out of the LMC and place it on the second ball stack. Then, they install the failed CMG in the opening vacated by the new CMG on the cargo bay carrier, tightening three bolts and two adjustable shims each with PGTs.

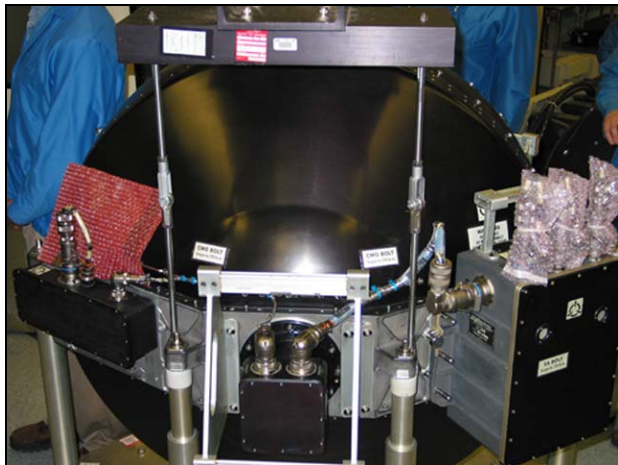

A replacement Control Moment Gyroscope is prepared for launch aboard Discovery

Still on the end of the Station’s robotic arm, Noguchi will hold the new CMG while Robinson disconnects it from the ball stack holding it to the CMG carrier. Arm operators will maneuver Noguchi and the new CMG to the Z1 truss, where Noguchi will insert the new CMG into the empty cavity. Meanwhile, Robinson will move back to the Z1, managing tethers and reporting clearances to help the robotic arm operators. Once the new CMG is “soft docked” in its cavity (no shims are required), Noguchi will tighten four bolts and Robinson two. After applying the right amount of torque to the bolts using PGTs, the pair will secure the new attitude control device. In careful coordinating with ground controllers,

Noguchi will mate four connectors to the jacks in the Z1 truss.

He and Robinson then will reinstall the thermal shroud over the new CMG, reinstall the floodlight, and move back to the cargo bay for cleanup and return to the Shuttle airlock.

EVA 3

Robinson and Noguchi will work together on all tasks for the third and final spacewalk of the mission, to be conducted on Flight Day 9. On tap are installation of a camera and illuminator package on the port truss structure of the Station, installation of ESP-2, retrieval of two Materials International Space Station Experiment (MISSE) packages and the installation of one new package, MISSE 5 - the first such experiment to have battery power and wireless data transmission capabilities. Several get-ahead tasks for future spacewalks may be accomplished if time allows.

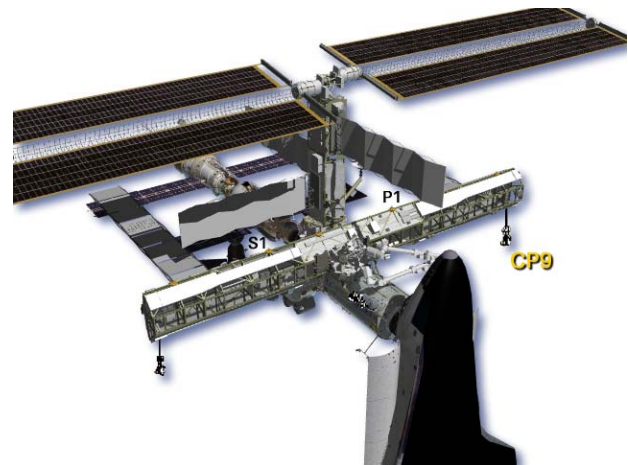

A television camera, lighting unit and Video Stanchion Support Assembly bracket will be installed at Camera Port 9

After exiting the Shuttle airlock with the camera group and ensuring their suits and tools are ready, Noguchi will go to the Video Stanchion Support Assembly (VSSA) in the cargo bay to retrieve the stanchion, while Robinson removes an orbiter power cable from ESP-2 in

preparation for its removal. Noguchi will remove two launch bolts and float with the stanchion to the port side of the Shuttle's docking system, positioning it so that Robinson can remove several bolts holding a connector-protecting dummy box. Next, Robinson will install the camera group in its stanchion and secure it with three bolts using a PGT. Together, they will move hand-over-hand to the Camera Position 9 worksite at the end of the P1 truss on the Earth-facing side. Noguchi will position the stanchion and use a PGT to engage one bolt that anchors the package to the truss. While Robinson removes one end of the power and data cables from dummy jacks on the VSSA, Noguchi will remove dust caps from the real jacks on the P1 truss and then mate the three cable connectors to the appropriate jacks. Robinson will remove a protective cover from the illuminator and unlock the camera's pan and tilt mechanism.

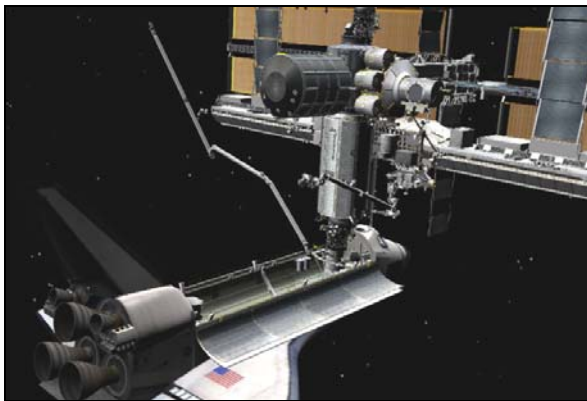

External Stowage Platform-2 is installed on the External Stowage Platform Attachment Device and Quest Airlock

During the camera group installation task, Kelly and Lawrence will use the Station's robotic crane to grapple the ESP-2 in Discovery's cargo bay and move it into position alongside the Quest airlock, where its ESPAD attachment mechanism was installed during EVA 1. Once the ESP-2 is in position, Robinson and Noguchi will help Kelly and Lawrence carefully guide the ESP-2, and verify

that the ESPAD claw and latches are open and ready to latch. When Thomas inside the orbiting complex gives a "go," Noguchi can drive the capture claw closed using a PGT. With the claw firmly grasping ESP-2, the spacewalkers will manually close three lock-down bars on the V-shaped guides that helped steer it into place. Once the lock-down bars are closed, Noguchi and Robinson each will use PGTs to drive the locking bolts until they are secure. Robinson will retrieve and connect the primary and secondary power cables that were pre-positioned during EVA 1. The pair will wrap up their tasks by performing surveys of the newly installed spare parts rack and its power connections with their helmet-mounted cameras.

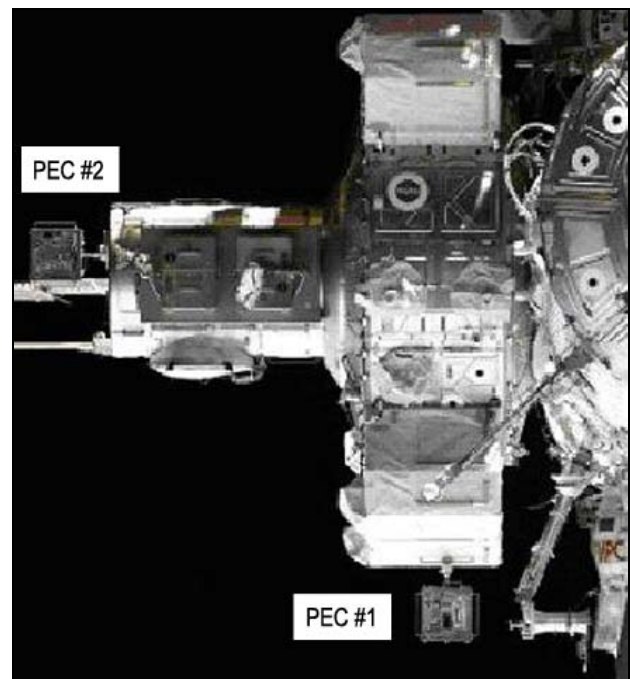

Two Materials International Space Station Experiment packages will be removed from the Quest Airlock and returned to Earth for examination

The last planned task of EVA 3 is the retrieval of two materials exposure experiments and the installation of a new one.

Robinson will use handrails to move to the end of the Quest crew lock and take photos of the

MISSE 2 experiment package before closing the experiment housing, releasing two PIP pins and removing the suitcase-like package. He'll place MISSE 2 in the Quest crew lock for temporary storage, then go to the MISSE 1 location. There, on the Earth-facing side of one of the dog house-shaped oxygen tanks mounted on the exterior of Quest's equipment lock, he'll perform the same steps on MISSE 2 and close the airlock thermal cover. Meanwhile, Noguchi will go to the Station airlock and retrieve a spare tether, a clamp and MISSE 5.

Moving along handrails, he'll travel to the uppermost point on the Space Station, the top of the P6 truss that holds the two large banks of American solar arrays. There, he'll install the clamp on a handrail on the P6's aft trunnion and lock MISSE 5 in place. Noguchi will turn the suitcase-like experiment inside-out, exposing its material samples to space. He'll ensure that the wireless antennas that will be used to transfer data are deployed. Those antennas function in the same way that the Station's amateur radio antennas do, and will allow commands to be sent to the experiment package. Telemetry from the experiments will be transmitted every three minutes to the United States Naval Academy near Washington, D.C. or other amateur radio receiving stations around the world. Noguchi will verify that the electronics are turned on before heading back to the Quest hatch.

Robinson will take care of one minor job on his way back to help Noguchi close the Station airlock hatch and clean up Discovery's cargo bay. He'll go to the newly installed ESP-2 and remove a Flight Releasable Grapple Fixture (FRGF) that would be in the way of an ORU installation planned for STS-121. He'll stow the FRGF in a Tool Stowage Assembly in the payload bay for the return home.

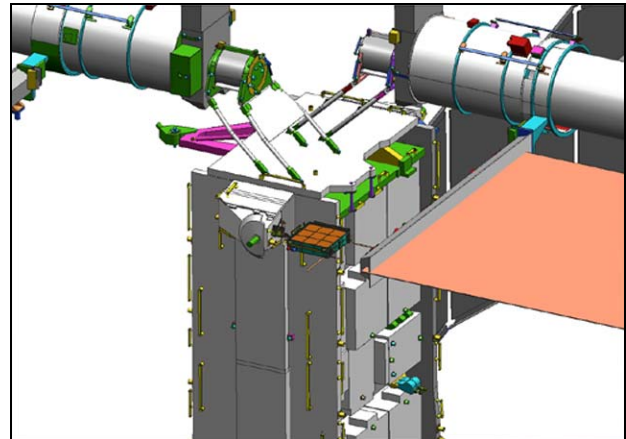

The first powered Materials International Space Station Experiment package, MISSE 5, will be installed at the top of the P6 truss

After Robinson repressurizes and opens the shuttle airlock, Noguchi will stow several tools and safety tethers in the Station airlock, and close the hatch and thermal cover and head back to the payload bay. Robinson will check the payload bay to be sure all equipment and tools are accounted. The pair then will re-enter the Shuttle airlock and close the hatch on the mission's final planned spacewalk.

PAYLOAD OVERVIEW



Space Shuttle Discovery will carry a variety of payloads. The flight will carry 29,725 pounds of equipment and supplies in its cargo bay to the International Space Station. When Discovery lands, it will return with 25,121 pounds of equipment in its cargo bay. Additional items will be carried on the Space Shuttle middeck including supplies, food, water and clothing for the crew.

The cargo bay measures 60 feet long and by 15 feet diameter and can carry the cargo equivalent to the size of a school bus. Under the Space Flight Operations Contract with United Space Alliance, Boeing performs the form, fit and function of any cargo that goes into the payload bay. The addition of the 50-foot boom and its suite of sensors called the Orbiter Boom Sensor System are considered to be part of the orbiter and are not considered part of the payload weight listed above.

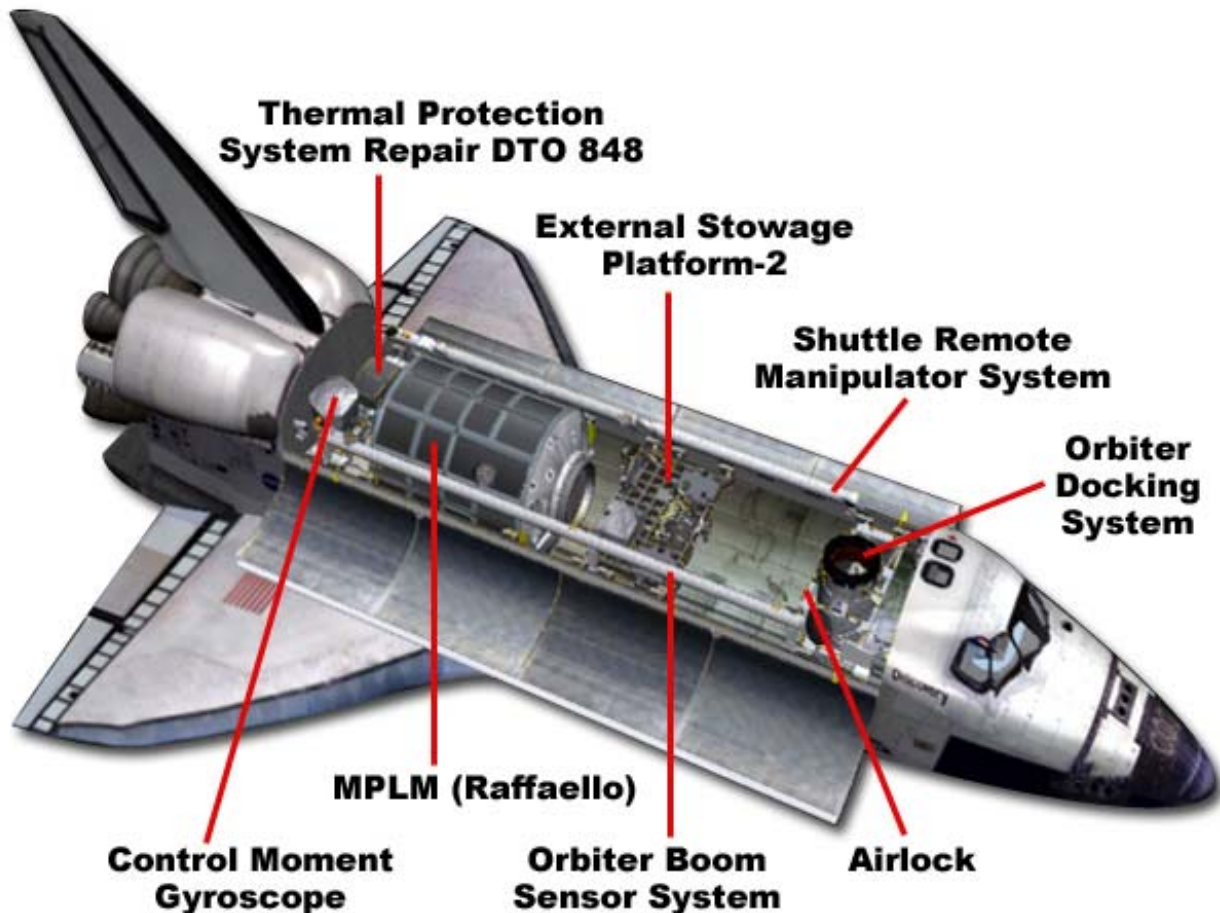

STS-114 Payload bay configuration

MULTI-PURPOSE LOGISTICS MODULE (MPLM) "RAFFAELLO"

The primary payload for this flight is the Italian-built Multi-Purpose Logistics Module, named Raffaello. The MPLM is a pressurized cargo container used to transport racks, equipment and supplies to the International Space Station. The MPLM is removed from the Space Shuttle cargo bay using the Station's arm and connected to the International Space Station using the Common Berthing Mechanism, which locks it in place with an airtight seal on the nadir side of the Station's Unity Module. The MPLM has a length of 22.4 feet and a diameter of 14.8 feet.



Multi-Purpose Logistics Module Raffaello in the Space Station Processing Facility.

Raffaello is the second MPLM built by the Italian Space Agency, serving as a reusable logistics carrier and primary delivery system to resupply and return station cargo requiring a pressurized environment.

EXTERNAL STOWAGE PLATFORM-2 (ESP-2)

Another item carried in the payload bay is the External Stowage Platform-2 (ESP-2). ESP-2 is an external pallet that can securely hold up to eight critical spare parts or Orbital Replacement Units for the Station. ESP-2 is a cross-bay carrier since it spans the width of the cargo bay and is used primarily to transport items to the Station. The astronauts will install ESP-2 during a spacewalk on the ninth day of the mission.

A third item carried in the payload bay is called the Lightweight Multipurpose Experiment Support Structure Carrier (LMC), which will be used to transport a replacement Control Moment Gyroscope (CMG) and the failed CMG on orbit back to Earth. The LMC also will carry a large box with a lid, called a Detailed Test Objective, that astronauts will open up to conduct several tile and reinforced carbon-carbon (RCC) panel repair experiments while on orbit. The experiment will check the proof of concept of one tile and one RCC panel repair method. The LMC is a cross-the-bay carrier as well. Astronauts will temporarily park the old CMG on the side of the LMC via a tether, remove the new one and install it, and then put the old CMG in the same spot as the new CMG when launched.

All three payloads will have electrical power drawn from the Space Shuttle for heaters to maintain the proper thermal environment while on orbit. A switch removes MPLM power electronically causing Remotely Operated Electrical Umbilical to disconnect, while the crew will have to physically disconnect power connectors to the ESP-2 and LMC.

MATERIALS INTERNATIONAL SPACE STATION EXPERIMENT (MISSE)

The only way to test how materials will perform in space is to test them in space. Laboratories can simulate only one or two space environmental factors at a time.

When Shuttle mission STS-105 lifted off from the Kennedy Space Center on Aug. 10, 2001, it carried the MISSE payload. The initial Materials International Space Station Experiment consisted of two "suitcases" (MISSE 1 and 2) full of materials that were to undergo an 18-month exposure test in space. The cases, called Passive Experiment Containers (PECs), were clamped to the exterior of the International Space Station by astronauts during a spacewalk. MISSE is the only externally mounted U.S. experiment to fly on the International Space Station.

Space is an extremely hazardous vacuum filled with lethal radiation, storms of micrometeoroids, extreme variations of temperature and all manner of man-made debris. Any one or a combination of these can damage or even destroy unshielded satellites and other spacecraft.

About 1,500 samples were tested on MISSE 1 and 2. The samples include ultralight membranes, composites, ceramics, polymers, coatings and radiation shielding. In addition, components such as switches, solar cells, sensors and mirrors will be evaluated for durability and survivability. Seeds, plant specimens and bacteria, furnished by students at the Wright Patterson Air Force Research Laboratory, are also being flown in specially designed containers.

During STS-114, astronauts will remove the original MISSE PECs (1 & 2) from the Station and install MISSE PEC 5. Like the myriad of samples in MISSE PECs 1 & 2, MISSE PEC 5 will study the degradation of solar cell samples in the space environment. PECs 1 & 2 will be returned to NASA Langley Research Center where they will be opened in a clean room and contents distributed to researchers for study. Additionally, MISSE PECs 3 and 4 will be launched on STS-121 (July 2005) and placed in the same location that 1 and 2 previously

occupied. PECs 3, 4 and 5 will all remain on orbit for one year to continue to study the effects of space exposure on various materials. The MISSE PECs are integrated and flown under the direction of the Department of Defense Space Test Program's Human Space Flight Payloads Office at NASA's Johnson Space Center.

EXPERIMENTS

DSOs AND DTOs



Detailed Supplementary Objectives (DSOs) are space and life science investigations. Their purpose is to:

- Determine the extent of physiological deconditioning resulting from spaceflight
- Test countermeasures to those changes
- Characterize the environment of the Space Shuttle and/or Space Station relative to crew health

Detailed Test Objectives (DTOs) are aimed at testing, evaluating or documenting Space Shuttle systems or hardware, or proposed improvements to the Space Shuttle or Space Station hardware, systems and operations.

Such experiments assigned to STS-114 are listed below.

DETAILED SUPPLEMENTARY OBJECTIVES

DSO 206 EFFECT OF SPACE FLIGHT ON BONE, MUSCLE AND IMMUNE FUNCTION(PRE/POST FLIGHT ONLY)

The primary objective of this study is to investigate the basic mechanism of the effects of spaceflight on the musculoskeletal system and immune function during long-term spaceflight. The accumulation of these baseline data will lead to the development of countermeasures for physiological changes of musculoskeletal system and immune function during long-term spaceflight.

DSO 490B BIOAVAILABILITY AND PERFORMANCE EFFECTS OF PROMETHAZINE DURING SPACE FLIGHT, PROTOCOL B

Promethazine (PMZ) is the anti-motion sickness medication of choice for treating space motion sickness (SMS) during Shuttle missions. The side effects associated with PMZ include dizziness, drowsiness, sedation and impaired psychomotor performance, which could affect crew performance of mission operations. Early reports from crewmembers indicate that these central nervous system side effects of PMZ are absent or greatly reduced in microgravity. The pharmacokinetics and bioavailability of medications administered in microgravity may be different than on Earth. This could significantly alter drug efficacy as well as severity of side effects for a given dosage. Therefore, systematic evaluation of PMZ bioavailability, effects on performance, side effects and efficacy in the treatment of SMS are essential for determining optimal dosage and route of administration of PMZ in flight.

DSO 493 MONITORING LATENT VIRUS REACTIVATION AND SHEDDING IN ASTRONAUTS

The premise of this DSO is that the incidence and duration of latent virus reactivation in saliva and urine will increase during spaceflight. The objective is to determine the frequency of induced reactivation of latent viruses, latent virus shedding and clinical disease after exposure to the physical, physiological and psychological stressors associated with spaceflight.

Spaceflight-induced alterations in the immune response become increasingly important on long

missions, particularly the potential for reactivation and dissemination (shedding) of latent viruses. An example of a latent virus is herpes simplex type-1 (HSV-1), which infects 70 to 80 percent of all adults. Its classic manifestations are cold sores, pharyngitis, and tonsillitis. It usually is acquired through contact with the saliva, skin or mucous membranes of an infected individual. However, many recurrences are asymptomatic, resulting in shedding of the virus.

DSO 498 SPACE FLIGHT AND IMMUNE FUNCTION (PRE/POST FLIGHT ONLY)

Astronauts face an increasing risk of contracting infectious diseases as they work and live for longer periods in the crowded conditions and closed environments of spacecraft such as the International Space Station. The effects of spaceflight on the human immune system, which plays a pivotal role in warding off infections, is not fully understood. Understanding the changes in immune function caused by exposure to microgravity will allow researchers to develop countermeasures to minimize the risk of infection.

The objective of this DSO is to characterize the effects of spaceflight on neutrophils, monocytes and cytotoxic cells, which play an important role in maintaining an effective defense against infectious agents. The premise of this study is that the space environment alters the essential functions of these elements of human immune response.

Researchers will conduct a functional analysis of neutrophils and monocytes from blood samples taken from astronauts before and after the flight. They will assess the subjects' pre- and post-flight production of cytotoxic cells and cytokine.

This study will complement previous and continuing immunology studies of astronauts' adaptation to space.

DSO 499 EYE MOVEMENTS AND MOTION PERCEPTION INDUCED BY OFF-VERTICAL AXIS ROTATION (OVAR) AT SMALL ANGLES OF TILT AFTER SPACEFLIGHT (PRE/POST FLIGHT ONLY)

Sensorimotor adaptation to the absence of gravity during orbital flight leads to perceptual and motor coordination problems upon return to Earth. Researchers hypothesize that there are adaptive changes in how the central nervous system processes gravitational tilt information for the vestibular (otolith) system. Eye movements and perceptual responses during constant velocity off-vertical axis rotation will reflect changes in otolith function as crewmembers readapt to Earth's gravity. The time course of recovery will be a function of flight duration.

The purpose of this study is to examine changes in spatial neural processing of gravitational tilt information following adaptation to microgravity. Post-flight oculomotor and perceptual responses during off-vertical axis rotation will be compared with pre-flight baselines to track the time course of recovery.

Comparison of data from short-duration and long-duration (International Space Station) crewmembers will allow researchers to assess the effect of flight duration.

DSO 500 SPACE FLIGHT INDUCED REACTIVATION OF LATENT EPSTEIN-BARR VIRUS (PRE/POST FLIGHT ONLY)

The effects of microgravity, along with associated physical and psychological stress, decrease Epstein-Barr virus (EBV)-specific T-cell immunity and reactivate latent EBV in infected

B-lymphocytes. DSO 500 will examine the mechanisms of spaceflight-induced alterations in human immune function and latent virus reactivation. Specifically, this study will determine the magnitude of immunosuppression as a result of spaceflight by analyzing stress hormones, performing quantitative analysis of EBV replication using molecular and serological methods and determining virus-specific T-cell immune function.

DSO 504 MICROGRAVITY INDUCED CHANGES IN THE CONTROL OF MUSCLES (PRE/POST FLIGHT ONLY)

Microgravity-induced detriments in muscle function may be mediated through two factors: 1) changes in muscle mass and mechanical properties, and 2) the control of muscles by the central nervous system. While there have been a number of studies addressing the atrophy and fiber type change in astronauts, the effects of microgravity on the control aspects of muscles have received little attention. The proposed work is directed toward filling this knowledge gap by focusing on the microgravity-induced changes in the neural control of muscles.

The overall goal of this project is to investigate the effects of microgravity on the neural control of motor units with a given muscle and the coordination of a group of muscles controlling a given joint. The primary objectives for this experiment are:

1. Document the effects of microgravity on the control of motor units in an antigravity muscle of the leg.
2. Study the effects of microgravity on a hand muscle.
3. Study the effects of microgravity on the activation of a group of muscles controlling one joint.

4. Determine the course of recovery after being re-exposed to gravity.

DETAILED TEST OBJECTIVES

DTO 805 CROSSWIND LANDING PERFORMANCE (DTO OF OPPORTUNITY)

The purpose of this DTO is to demonstrate the capability to perform a manually controlled landing in the presence of a crosswind. The testing is done in two steps.

1. Pre-launch: Ensure planning will allow selection of a runway with Microwave Scanning Beam Landing System support, which is a set of dual transmitters located beside the runway providing precision navigation vertically, horizontally and longitudinally with respect to the runway. This precision navigation subsystem helps provide a higher probability of a more precise landing with a crosswind of 10 to 15 knots as late in the flight as possible.
2. Entry: This test requires that the crew perform a manually controlled landing in the presence of a 90-degree crosswind component of 10 to 15 knots steady state.

During a crosswind landing, the drag chute will be deployed after nose gear touchdown when the vehicle is stable and tracking the runway centerline.

DTO 848 ORBITER THERMAL PROTECTION SYSTEM (TPS) REPAIR TECHNIQUES

For this DTO, STS-114 crewmembers Soichi Noguchi and Steve Robinson will conduct a spacewalk side-by-side in Discovery's cargo bay at a pallet carrying a variety of damaged Shuttle tiles and reinforced carbon-carbon samples. Noguchi will work on tile repair, demonstrating the use of an Emittance Wash Applicator and associated tools. Robinson will work with the reinforced carbon-carbon. (See "Spacewalk" section for more details.)

RCC Repair Objectives:

- Evaluate the working life/workability of the NOAX (Non-Oxide Adhesive Experimental) Crack Repair material application.

Tile Repair Objectives:

- Emittance Wash Applicator - Demonstrate application of the Emittance Wash material onto a damaged sample tile.

DTO 850 WATER SPRAY BOILER COOLING WITH WATER/PGME ANTIFREEZE

Water spray boilers, after spraying water, freeze every time auxiliary power units are shut down and remain frozen for unpredictable amounts of time. A solution is to replace water as the cooling fluid in the water spray boiler tank with an azeotropic mixture of 53 percent water and 47 percent propylene glycol monomethyl ether (PGME). Tests done at White Sands Test Facility in New Mexico show that a water/PGME mixture is not likely to freeze in the conditions seen on orbit. A water/PGME mixture turns to slush at about -40 degrees Fahrenheit and freezes at -54 degrees F.

The plan is to fill only water spray boiler No. 3 water tank with a water/PGME mixture for STS-114 and STS-121. The primary objective is to confirm ground test results for water spray boiler in the post-ascent, high-vacuum, zero-G environment. A secondary objective is to confirm coolant usage is within predictions.

The pilot will perform the water spray boiler cooling verification.

SHUTTLE REFERENCE DATA

SHUTTLE ABORT MODES

RSLs Aborts

These occur when the on-board Shuttle computers detect a problem and command a halt in the launch sequence after taking over from the Ground Launch Sequencer and before Solid Rocket Booster ignition.

Ascent Aborts

Selection of an ascent abort mode may become necessary if there is a failure that affects vehicle performance, such as the failure of a Space Shuttle main engine or an orbital maneuvering system. Other failures requiring early termination of a flight, such as a cabin leak, might also require the selection of an abort mode. There are two basic types of ascent abort modes for Space Shuttle missions: intact aborts and contingency aborts. Intact aborts are designed to provide a safe return of the orbiter to a planned landing site. Contingency aborts are designed to permit flight crew survival following more severe failures when an intact abort is not possible. A contingency abort would generally result in a ditch operation.

Intact Aborts

There are four types of intact aborts: abort to orbit (ATO), abort once around (AOA), transoceanic abort landing (TAL) and return to launch site (RTLs).

Return to Launch Site

The RTLs abort mode is designed to allow the return of the orbiter, crew and payload to the launch site, Kennedy Space Center, approximately 25 minutes after liftoff.

The RTLs profile is designed to accommodate the loss of thrust from one Space Shuttle main

engine between liftoff and approximately four minutes 20 seconds, at which time not enough main propulsion system propellant remains to return to the launch site. An RTLs can be considered to consist of three stages--a powered stage, during which the Space Shuttle main engines are still thrusting; an External Tank separation phase; and the glide phase, during which the orbiter glides to a landing at the Kennedy Space Center. The powered RTLs phase begins with the crew selection of the RTLs abort, which is done after solid rocket booster separation. The crew selects the abort mode by positioning the abort rotary switch to RTLs and depressing the abort push button. The time at which the RTLs is selected depends on the reason for the abort. For example, a three-engine RTLs is selected at the last moment, about 3 minutes, 34 seconds into the mission; whereas an RTLs chosen due to an engine out at liftoff is selected at the earliest time, about 2 minutes, 20 seconds into the mission (after solid rocket booster separation).

After RTLs is selected, the vehicle continues downrange to dissipate excess main propulsion system propellant. The goal is to leave only enough main propulsion system propellant to be able to turn the vehicle around, fly back toward the Kennedy Space Center and achieve the proper main engine cutoff conditions so the vehicle can glide to the Kennedy Space Center after external tank separation. During the downrange phase, a pitch-around maneuver is initiated (the time depends in part on the time of a Space Shuttle main engine failure) to orient the orbiter/external tank configuration to a heads-up attitude, pointing toward the launch site. At this time, the vehicle is still moving away from the launch site, but the Space Shuttle main

engines are now thrusting to null the downrange velocity. In addition, excess orbital maneuvering system and reaction control system propellants are dumped by continuous orbital maneuvering system and reaction control system engine thrustings to improve the orbiter weight and center of gravity for the glide phase and landing.

The vehicle will reach the desired main engine cutoff point with less than 2 percent excess propellant remaining in the external tank. At main engine cutoff minus 20 seconds, a pitch down maneuver (called powered pitch-down) takes the mated vehicle to the required external tank separation attitude and pitch rate. After main engine cutoff has been commanded, the external tank separation sequence begins, including a reaction control system translation that ensures that the orbiter does not recontact the external tank and that the orbiter has achieved the necessary pitch attitude to begin the glide phase of the RTLS.

After the reaction control system translation maneuver has been completed, the glide phase of the RTLS begins. From then on, the RTLS is handled similarly to a normal entry.

Transoceanic Abort Landing

The TAL abort mode was developed to improve the options available when a Space Shuttle main engine fails after the last RTLS opportunity but before the first time that an AOA can be accomplished with only two Space Shuttle main engines or when a major orbiter system failure, for example, a large cabin pressure leak or cooling system failure, occurs after the last RTLS opportunity, making it imperative to land as quickly as possible.

In a TAL abort, the vehicle continues on a ballistic trajectory across the Atlantic Ocean to land at a predetermined runway. Landing occurs about 45 minutes after launch. The landing site is selected near the nominal ascent

ground track of the orbiter to make the most efficient use of Space Shuttle main engine propellant. The landing site also must have the necessary runway length, weather conditions and U.S. State Department approval. The three landing sites that have been identified for a due east launch are Zaragoza, Spain; Moron, Spain; and Istres, France.

To select the TAL abort mode, the crew must place the abort rotary switch in the TAL/ AOA position and depress the abort push button before main engine cutoff. (Depressing it after main engine cutoff selects the AOA abort mode.) The TAL abort mode begins sending commands to steer the vehicle toward the plane of the landing site. It also rolls the vehicle heads up before main engine cutoff and sends commands to begin an orbital maneuvering system propellant dump (by burning the propellants through the orbital maneuvering system engines and the reaction control system engines). This dump is necessary to increase vehicle performance (by decreasing weight), to place the center of gravity in the proper place for vehicle control and to decrease the vehicle's landing weight. TAL is handled like a nominal entry.

Abort to Orbit

An ATO is an abort mode used to boost the orbiter to a safe orbital altitude when performance has been lost and it is impossible to reach the planned orbital altitude. If a Space Shuttle main engine fails in a region that results in a main engine cutoff under speed, the Mission Control Center will determine that an abort mode is necessary and will inform the crew. The orbital maneuvering system engines would be used to place the orbiter in a circular orbit.

Abort Once Around

The AOA abort mode is used in cases in which vehicle performance has been lost to such an extent that either it is impossible to achieve a viable orbit or not enough orbital maneuvering

system propellant is available to accomplish the orbital maneuvering system thrusting maneuver to place the orbiter on orbit and the deorbit thrusting maneuver. In addition, an AOA is used in cases in which a major systems problem (cabin leak, loss of cooling) makes it necessary to land quickly. In the AOA abort mode, one orbital maneuvering system thrusting sequence is made to adjust the post-main engine cutoff orbit so a second orbital maneuvering system thrusting sequence will result in the vehicle deorbiting and landing at the AOA landing site (White Sands, N.M.; Edwards Air Force Base; or the Kennedy Space Center). Thus, an AOA results in the orbiter circling the Earth once and landing about 90 minutes after liftoff.

After the deorbit thrusting sequence has been executed, the flight crew flies to a landing at the planned site much as it would for a nominal entry.

CONTINGENCY ABORTS

Contingency aborts are caused by loss of more than one main engine or failures in other systems. Loss of one main engine while another is stuck at a low thrust setting may also necessitate a contingency abort. Such an abort would maintain orbiter integrity for in-flight crew escape if a landing cannot be achieved at a suitable landing field.

Contingency aborts due to system failures other than those involving the main engines would normally result in an intact recovery of vehicle and crew. Loss of more than one main engine may, depending on engine failure times, result in a safe runway landing. However, in most three-engine-out cases during ascent, the orbiter would have to be ditched. The in-flight crew escape system would be used before ditching the orbiter.

Abort Decisions

There is a definite order of preference for the various abort modes. The type of failure and the time of the failure determine which type of abort is selected. In cases where performance loss is the only factor, the preferred modes would be ATO, AOA, TAL and RTLS, in that order. The mode chosen is the highest one that can be completed with the remaining vehicle performance.

In the case of some support system failures, such as cabin leaks or vehicle cooling problems, the preferred mode might be the one that will end the mission most quickly. In these cases, TAL or RTLS might be preferable to AOA or ATO. A contingency abort is never chosen if another abort option exists.

The Mission Control Center-Houston is prime for calling these aborts because it has a more precise knowledge of the orbiter's position than the crew can obtain from on-board systems. Before main engine cutoff, Mission Control makes periodic calls to the crew to tell them which abort mode is (or is not) available. If ground communications are lost, the flight crew has on-board methods, such as cue cards, dedicated displays and display information, to determine the abort region.

Which abort mode is selected depends on the cause and timing of the failure causing the abort and which mode is safest or improves mission success. If the problem is a Space Shuttle main engine failure, the flight crew and Mission Control Center select the best option available at the time a main engine fails.

If the problem is a system failure that jeopardizes the vehicle, the fastest abort mode that results in the earliest vehicle landing is chosen. RTLS and TAL are the quickest options (35 minutes), whereas an AOA requires about 90 minutes. Which of these is selected depends on the time of the failure with three good Space Shuttle main engines.

The flight crew selects the abort mode by positioning an abort mode switch and depressing an abort push button.

SHUTTLE ABORT HISTORY

RSLs Abort History: (STS-41 D) June 26, 1984

The countdown for the second launch attempt for Discovery's maiden flight ended at T-4 seconds when the orbiter's computers detected a sluggish valve in main engine No. 3. The main engine was replaced and Discovery was finally launched on Aug. 30, 1984.

(STS-51 F) July 12, 1985

The countdown for Challenger's launch was halted at T-3 seconds when on-board computers detected a problem with a coolant valve on main engine No. 2. The valve was replaced and Challenger was launched on July 29, 1985.

(STS-55) March 22, 1993

The countdown for Columbia's launch was halted by on-board computers at T-3 seconds following a problem with purge pressure readings in the oxidizer preburner on main engine No. 2. Columbia's three main engines were replaced on the launch pad, and the flight was rescheduled behind Discovery's launch on STS-56. Columbia finally launched on April 26, 1993.

(STS-51) Aug. 12, 1993

The countdown for Discovery's third launch attempt ended at the T-3 second mark when onboard computers detected the failure of one of four sensors in main engine No. 2 which monitor the flow of hydrogen fuel to the engine. All of Discovery's main engines were ordered replaced on the launch pad, delaying

the Shuttle's fourth launch attempt until Sept. 12, 1993.

(STS-68) August 18, 1994

The countdown for Endeavour's first launch attempt ended 1.9 seconds before liftoff when on-board computers detected higher than acceptable readings in one channel of a sensor monitoring the discharge temperature of the high pressure oxidizer turbopump in main engine No. 3. A test firing of the engine at the Stennis Space Center in Mississippi on September 2nd confirmed that a slight drift in a fuel flow meter in the engine caused a slight increase in the turbopump's temperature. The test firing also confirmed a slightly slower start for main engine No. 3 during the pad abort, which could have contributed to the higher temperatures. After Endeavour was brought back to the Vehicle

Assembly Building to be outfitted with three replacement engines, NASA managers set Oct. 2 as the date for Endeavour's second launch attempt.

Abort to Orbit History: (STS-51 F) July 29, 1985

After an RSLs abort on July 12, 1985, Challenger was launched on July 29, 1985. Five minutes and 45 seconds after launch, a sensor problem resulted in the shutdown of center engine No. 1, resulting in a safe "abort to orbit" and successful completion of the mission.

SPACE SHUTTLE MAIN ENGINES

Developed in the 1970s by NASA's Marshall Space Flight Center in Huntsville, Ala., the Space Shuttle Main Engine is the most advanced liquid-fueled rocket engine ever built. Its main features include variable thrust, high performance, reusability, high redundancy and a fully integrated engine controller.

The Shuttle's three main engines are mounted on the orbiter aft fuselage in a triangular pattern. Spaced so that they are movable during launch, the engines are used - in conjunction with the Solid Rocket Boosters - to steer the Shuttle vehicle.

Each of these powerful main engines is 14 feet (4.2 meters) long, weighs about 7,000 pounds (3,150 kilograms) and is 7.5 feet (2.25 meters) in diameter at the end of its nozzle.

The engines operate for about 8 1/2 minutes during liftoff and ascent -- burning more than 500,000 gallons (1.9 million liters) of super-cold liquid hydrogen and liquid oxygen propellants stored in the huge external tank attached to the underside of the Shuttle. The engines shut down just before the Shuttle, traveling at about 17,000 mph (28,000 kilometers per hour), reaches orbit.

The main engine operates at greater temperature extremes than any mechanical system in common use today. The fuel, liquefied hydrogen at -423 degrees Fahrenheit (-253 degrees Celsius), is the second coldest liquid on Earth. When it and the liquid oxygen are combusted, the temperature in the main combustion chamber is 6,000 degrees Fahrenheit (3,316 degrees Celsius), hotter than the boiling point of iron.

The main engines use a staged combustion cycle so that all propellants entering the engines are used to produce thrust or power -- more efficiently than any previous rocket engine. In a staged combustion cycle, propellants are first burned partially at high pressure and relatively low temperature -- then burned completely at high temperature and pressure in the main combustion chamber. The rapid mixing of the propellants under these conditions is so complete that 99 percent of the fuel is burned.

At normal operating level, the engines generate 490,847 pounds of thrust (measured

in a vacuum). Full power is 512,900 pounds of thrust; minimum power is 316,100 pounds of thrust.

The engine can be throttled by varying the output of the pre-burners, thus varying the speed of the high-pressure turbopumps and, therefore, the flow of the propellant.

At about 26 seconds into launch, the main engines are throttled down to 316,000 pounds of thrust to keep the dynamic pressure on the vehicle below a specified level -- about 580 pounds per square foot or max q. Then, the engines are throttled back up to normal operating level at about 60 seconds. This reduces stress on the vehicle.

The main engines are throttled down again at about seven minutes, 40 seconds into the mission to maintain three g's - three times the Earth's gravitational pull - again reducing stress on the crew and the vehicle. This acceleration level is about one-third the acceleration experienced on previous crewed space vehicles.

About 10 seconds before Main Engine Cutoff or MECO, the cutoff sequence begins; about three seconds later the main engines are commanded to begin throttling at 10 percent thrust per second to 65 percent thrust. This is held for about 6.7 seconds, and the engines are shut down.

The engine performance has the highest thrust for its weight of any engine yet developed. In fact, one Space Shuttle Main Engine generates sufficient thrust to maintain the flight of 2 1/2 747 airplanes.

The Space Shuttle Main Engine is also the first rocket engine to use a built-in electronic digital controller, or computer. The controller will accept commands from the orbiter for engine start, change in throttle, shutdown, and monitor engine operation. In the event of a failure, the

controller automatically corrects the problem or safely shuts down the engine.

NASA continues to increase the reliability and safety of Shuttle flights through a series of enhancements to the Space Shuttle Main Engines. The engines were modified in 1988, 1995, 1998 and 2001. Modifications include new high-pressure fuel and oxidizer turbopumps that reduce maintenance and operating costs of the engine, a two-duct powerhead that reduces pressure and turbulence in the engine, and a single-coil heat exchanger that lowers the number of post flight inspections required. Another modification incorporates a large-throat main combustion chamber that improves the engine's reliability by reducing pressure and temperature in the chamber.

After the orbiter lands, the engines are removed and returned to a processing facility at Kennedy Space Center, Fla., where they are rechecked and readied for the next flight. Some components are returned to the main engine's prime contractor, Rocketdyne Propulsion & Power unit of the Boeing Company, Canoga Park, Calif., for regular maintenance. The main engines are designed to operate for 7.5 accumulated hours.

SPACE SHUTTLE SOLID ROCKET BOOSTERS

The two SRBs provide the main thrust to lift the Space Shuttle off the pad and up to an altitude of about 150,000 feet, or 24 nautical miles (28 statute miles). In addition, the two SRBs carry the entire weight of the external tank and orbiter and transmit the weight load through their structure to the mobile launcher platform.

Each booster has a thrust (sea level) of about 3,300,000 pounds at launch. They are ignited after the three Space Shuttle main engines'

thrust level is verified. The two SRBs provide 71.4 percent of the thrust at liftoff and during first-stage ascent. Seventy-five seconds after SRB separation, SRB apogee occurs at an altitude of about 220,000 feet, or 35 nautical miles (40 statute miles). SRB impact occurs in the ocean about 122 nautical miles (140 statute miles) downrange.

The SRBs are the largest solid-propellant motors ever flown and the first designed for reuse. Each is 149.16 feet long and 12.17 feet in diameter.

Each SRB weighs about 1,300,000 pounds at launch. The propellant for each solid rocket motor weighs about 1,100,000 pounds. The inert weight of each SRB is about 192,000 pounds.

Primary elements of each booster are the motor (including case, propellant, igniter and nozzle), structure, separation systems, operational flight instrumentation, recovery avionics, pyrotechnics, deceleration system, thrust vector control system and range safety destruct system.

Each booster is attached to the external tank at the SRB's aft frame by two lateral sway braces and a diagonal attachment. The forward end of each SRB is attached to the external tank at the forward end of the SRB's forward skirt. On the launch pad, each booster also is attached to the mobile launcher platform at the aft skirt by four bolts and nuts that are severed by small explosives at liftoff.

During the downtime following the Challenger accident, detailed structural analyses were performed on critical structural elements of the SRB. Analyses were primarily focused in areas where anomalies had been noted during postflight inspection of recovered hardware.

One of the areas was the attach ring where the SRBs are connected to the external tank. Areas of distress were noted in some of the fasteners where the ring attaches to the SRB motor case. This situation was attributed to the high loads

encountered during water impact. To correct the situation and ensure higher strength margins during ascent, the attach ring was redesigned to encircle the motor case completely (360 degrees). Previously, the attach ring formed a C and encircled the motor case 270 degrees.

Additionally, special structural tests were done on the aft skirt. During this test program, an anomaly occurred in a critical weld between the hold-down post and skin of the skirt. A redesign was implemented to add reinforcement brackets and fittings in the aft ring of the skirt.

These two modifications added about 450 pounds to the weight of each SRB.

The propellant mixture in each SRB motor consists of an ammonium perchlorate (oxidizer, 69.6 percent by weight), aluminum (fuel, 16 percent), iron oxide (a catalyst, 0.4 percent), a polymer (a binder that holds the mixture together, 12.04 percent), and an epoxy curing agent (1.96 percent). The propellant is an 11-point star-shaped perforation in the forward motor segment and a double-truncated-cone perforation in each of the aft segments and aft closure. This configuration provides high thrust at ignition and then reduces the thrust by about a third 50 seconds after liftoff to prevent overstressing the vehicle during maximum dynamic pressure.

The SRBs are used as matched pairs and each is made up of four solid rocket motor segments. The pairs are matched by loading each of the four motor segments in pairs from the same batches of propellant ingredients to minimize any thrust imbalance. The segmented-casing design assures maximum flexibility in fabrication and ease of transportation and handling. Each segment is shipped to the launch site on a heavy-duty rail car with a specially built cover.

The nozzle expansion ratio of each booster beginning with the STS-8 mission is 7-to-79. The nozzle is gimbled for thrust vector (direction) control. Each SRB has its own redundant auxiliary power units and hydraulic pumps. The all-axis gimbaling capability is 8 degrees. Each nozzle has a carbon cloth liner that erodes and chars during firing. The nozzle is a convergent-divergent, movable design in which an aft pivot-point flexible bearing is the gimbal mechanism.

The cone-shaped aft skirt reacts the aft loads between the SRB and the mobile launcher platform. The four aft separation motors are mounted on the skirt. The aft section contains avionics, a thrust vector control system that consists of two auxiliary power units and hydraulic pumps, hydraulic systems and a nozzle extension jettison system.

The forward section of each booster contains avionics, a sequencer, forward separation motors, a nose cone separation system, drogue and main parachutes, a recovery beacon, a recovery light, a parachute camera on selected flights and a range safety system.

Each SRB has two integrated electronic assemblies, one forward and one aft. After burnout, the forward assembly initiates the release of the nose cap and frustum and turns on the recovery aids. The aft assembly, mounted in the external tank/SRB attach ring, connects with the forward assembly and the orbiter avionics systems for SRB ignition commands and nozzle thrust vector control. Each integrated electronic assembly has a multiplexer/demultiplexer, which sends or receives more than one message, signal or unit of information on a single communication channel.

Eight booster separation motors (four in the nose frustum and four in the aft skirt) of each SRB thrust for 1.02 seconds at SRB separation from the external tank. Each solid rocket separation motor is 31.1 inches long and 12.8 inches in diameter.

Location aids are provided for each SRB, frustum/drogue chutes and main parachutes. These include a transmitter, antenna, strobe/converter, battery and salt-water switch electronics. The location aids are designed for a minimum operating life of 72 hours and when refurbished are considered usable up to 20 times. The flashing light is an exception. It has an operating life of 280 hours. The battery is used only once.

The SRB nose caps and nozzle extensions are not recovered.

The recovery crew retrieves the SRBs, frustum/drogue chutes, and main parachutes. The nozzles are plugged, the solid rocket motors are dewatered, and the SRBs are towed back to the launch site. Each booster is removed from the water, and its components are disassembled and washed with fresh and deionized water to limit salt-water corrosion. The motor segments, igniter and nozzle are shipped back to ATK Thiokol for refurbishment.

Each SRB incorporates a range safety system that includes a battery power source, receiver/decoder, antennas and ordnance.

Hold-Down Posts

Each solid rocket booster has four hold-down posts that fit into corresponding support posts on the mobile launcher platform. Hold-down bolts hold the SRB and launcher platform posts together. Each bolt has a nut at each end, but only the top nut is frangible. The top nut contains two NASA standard detonators, which are ignited at solid rocket motor ignition commands.

When the two NSDs are ignited at each hold-down, the hold-down bolt travels downward because of the release of tension in the bolt (pretensioned before launch), NSD gas pressure and gravity. The bolt is stopped by

the stud deceleration stand, which contains sand. The SRB bolt is 28 inches long and 3.5 inches in diameter. The frangible nut is captured in a blast container.

The solid rocket motor ignition commands are issued by the orbiter's computers through the master events controllers to the hold-down pyrotechnic initiator controllers on the mobile launcher platform. They provide the ignition to the hold-down NSDs. The launch processing system monitors the SRB hold-down PICs for low voltage during the last 16 seconds before launch. PIC low voltage will initiate a launch hold.

SRB Ignition

SRB ignition can occur only when a manual lock pin from each SRB safe and arm device has been removed. The ground crew removes the pin during prelaunch activities. At T minus five minutes, the SRB safe and arm device is rotated to the arm position. The solid rocket motor ignition commands are issued when the three SSMEs are at or above 90 percent rated thrust, no SSME fail and/or SRB ignition PIC low voltage is indicated and there are no holds from the LPS.

The solid rocket motor ignition commands are sent by the orbiter computers through the MECs to the safe and arm device NSDs in each SRB. A PIC single-channel capacitor discharge device controls the firing of each pyrotechnic device. Three signals must be present simultaneously for the PIC to generate the pyro firing output. These signals--arm, fire 1 and fire 2--originate in the orbiter general-purpose computers and are transmitted to the MECs. The MECs reformat them to 28-volt dc signals for the PICs. The arm signal charges the PIC capacitor to 40 volts dc (minimum of 20 volts dc).

The fire 2 commands cause the redundant NSDs to fire through a thin barrier seal down a flame tunnel. This ignites a pyro booster charge, which

is retained in the safe and arm device behind a perforated plate. The booster charge ignites the propellant in the igniter initiator; and combustion products of this propellant ignite the solid rocket motor initiator, which fires down the length of the solid rocket motor igniting the solid rocket motor propellant.

The GPC launch sequence also controls certain critical main propulsion system valves and monitors the engine-ready indications from the SSMEs. The MPS start commands are issued by the on-board computers at T minus 6.6 seconds (staggered start--engine three, engine two, engine one--all about within 0.25 of a second), and the sequence monitors the thrust buildup of each engine. All three SSMEs must reach the required 90 percent thrust within three seconds; otherwise, an orderly shutdown is commanded and safing functions are initiated.

Normal thrust buildup to the required 90 percent thrust level will result in the SSMEs being commanded to the liftoff position at T minus three seconds as well as the fire 1 command being issued to arm the SRBs. At T minus three seconds, the vehicle base bending load modes are allowed to initialize (movement of 25.5 inches measured at the tip of the external tank, with movement towards the external tank).

At T minus zero, the two SRBs are ignited under command of the four on-board computers; separation of the four explosive bolts on each SRB is initiated (each bolt is 28 inches long and 3.5 inches in diameter); the two T-0 umbilicals (one on each side of the spacecraft) are retracted; the on-board master timing unit, event timer and mission event timers are started; the three SSMEs are at 100 percent; and the ground launch sequence is terminated.

The solid rocket motor thrust profile is tailored to reduce thrust during the maximum dynamic pressure region.

Electrical Power Distribution

Electrical power distribution in each SRB consists of orbiter-supplied main dc bus power to each SRB via SRB buses A, B and C. Orbiter main dc buses A, B and C supply main dc bus power to corresponding SRB buses A, B and C. In addition, orbiter main dc bus C supplies backup power to SRB buses A and B, and orbiter bus B supplies backup power to SRB bus C. This electrical power distribution arrangement allows all SRB buses to remain powered in the event one orbiter main bus fails.

The nominal dc voltage is 28 volts dc, with an upper limit of 32 volts dc and a lower limit of 24 volts dc.

Hydraulic Power Units

There are two self-contained, independent HPUs on each SRB. Each HPU consists of an auxiliary power unit, fuel supply module, hydraulic pump, hydraulic reservoir and hydraulic fluid manifold assembly. The APUs are fueled by hydrazine and generate mechanical shaft power to a hydraulic pump that produces hydraulic pressure for the SRB hydraulic system. The two separate HPUs and two hydraulic systems are located on the aft end of each SRB between the SRB nozzle and aft skirt. The HPU components are mounted on the aft skirt between the rock and tilt actuators. The two systems operate from T minus 28 seconds until SRB separation from the orbiter and external tank. The two independent hydraulic systems are connected to the rock and tilt servoactuators.

The APU controller electronics are located in the SRB aft integrated electronic assemblies on the aft external tank attach rings.

The APUs and their fuel systems are isolated from each other. Each fuel supply module (tank) contains 22 pounds of hydrazine. The fuel tank is pressurized with gaseous nitrogen at 400 psi,

which provides the force to expel (positive expulsion) the fuel from the tank to the fuel distribution line, maintaining a positive fuel supply to the APU throughout its operation.

The fuel isolation valve is opened at APU startup to allow fuel to flow to the APU fuel pump and control valves and then to the gas generator. The gas generator's catalytic action decomposes the fuel and creates a hot gas. It feeds the hot gas exhaust product to the APU two-stage gas turbine. Fuel flows primarily through the startup bypass line until the APU speed is such that the fuel pump outlet pressure is greater than the bypass line's. Then all the fuel is supplied to the fuel pump.

The APU turbine assembly provides mechanical power to the APU gearbox. The gearbox drives the APU fuel pump, hydraulic pump and lube oil pump. The APU lube oil pump lubricates the gearbox. The turbine exhaust of each APU flows over the exterior of the gas generator, cooling it, and is then directed overboard through an exhaust duct.

When the APU speed reaches 100 percent, the APU primary control valve closes, and the APU speed is controlled by the APU controller electronics. If the primary control valve logic fails to the open state, the secondary control valve assumes control of the APU at 112 percent speed.

Each HPU on an SRB is connected to both servoactuators on that SRB. One HPU serves as the primary hydraulic source for the servoactuator, and the other HPU serves as the secondary hydraulics for the servoactuator. Each servoactuator has a switching valve that allows the secondary hydraulics to power the actuator if the primary hydraulic pressure drops below 2,050 psi. A switch contact on the switching valve will close when the valve is in the secondary position. When the valve is closed, a signal is sent to the APU controller that inhibits the 100 percent APU speed control

logic and enables the 112 percent APU speed control logic. The 100 percent APU speed enables one APU/HPU to supply sufficient operating hydraulic pressure to both servoactuators of that SRB.

The APU 100 percent speed corresponds to 72,000 rpm, 110 percent to 79,200 rpm, and 112 percent to 80,640 rpm.

The hydraulic pump speed is 3,600 rpm and supplies hydraulic pressure of 3,050, plus or minus 50, psi. A high-pressure relief valve provides overpressure protection to the hydraulic system and relieves at 3,750 psi.

The APUs/HPUs and hydraulic systems are reusable for 20 missions.

Thrust Vector Control

Each SRB has two hydraulic gimbal servoactuators: one for rock and one for tilt. The servoactuators provide the force and control to gimbal the nozzle for thrust vector control.

The Space Shuttle ascent thrust vector control portion of the flight control system directs the thrust of the three Shuttle main engines and the two SRB nozzles to control Shuttle attitude and trajectory during liftoff and ascent. Commands from the guidance system are transmitted to the ATVC drivers, which transmit signals proportional to the commands to each servoactuator of the main engines and SRBs. Four independent flight control system channels and four ATVC channels control six main engine and four SRB ATVC drivers, with each driver controlling one hydraulic port on each main and SRB servoactuator.

Each SRB servoactuator consists of four independent, two-stage servovalves that receive signals from the drivers. Each servovalve controls one power spool in each actuator, which positions an actuator ram and the nozzle to control the direction of thrust.

The four servovalves in each actuator provide a force-summed majority voting arrangement to position the power spool. With four identical commands to the four servovalves, the actuator force-sum action prevents a single erroneous command from affecting power ram motion. If the erroneous command persists for more than a predetermined time, differential pressure sensing activates a selector valve to isolate and remove the defective servovalve hydraulic pressure, permitting the remaining channels and servovalves to control the actuator ram spool.

Failure monitors are provided for each channel to indicate which channel has been bypassed. An isolation valve on each channel provides the capability of resetting a failed or bypassed channel.

Each actuator ram is equipped with transducers for position feedback to the thrust vector control system. Within each servoactuator ram is a splashdown load relief assembly to cushion the nozzle at water splashdown and prevent damage to the nozzle flexible bearing.

SRB Rate Gyro Assemblies

Each SRB contains two RGAs, with each RGA containing one pitch and one yaw gyro. These provide an output proportional to angular rates about the pitch and yaw axes to the orbiter computers and guidance, navigation and control system during first-stage ascent flight in conjunction with the orbiter roll rate gyros until SRB separation. At SRB separation, a switchover is made from the SRB RGAs to the orbiter RGAs.

The SRB RGA rates pass through the orbiter flight aft multiplexers/ demultiplexers to the orbiter GPCs. The RGA rates are then mid-value-selected in redundancy management to provide SRB pitch and yaw rates to the user

software. The RGAs are designed for 20 missions.

SRB Separation

SRB separation is initiated when the three solid rocket motor chamber pressure transducers are processed in the redundancy management middle value select and the head-end chamber pressure of both SRBs is less than or equal to 50 psi. A backup cue is the time elapsed from booster ignition.

The separation sequence is initiated, commanding the thrust vector control actuators to the null position and putting the main propulsion system into a second-stage configuration (0.8 second from sequence initialization), which ensures the thrust of each SRB is less than 100,000 pounds. Orbiter yaw attitude is held for four seconds, and SRB thrust drops to less than 60,000 pounds.

The SRBs separate from the external tank within 30 milliseconds of the ordnance firing command.

The forward attachment point consists of a ball (SRB) and socket (ET) held together by one bolt. The bolt contains one NSD pressure cartridge at each end. The forward attachment point also carries the range safety system cross-strap wiring connecting each SRB RSS and the ET RSS with each other.

The aft attachment points consist of three separate struts: upper, diagonal and lower. Each strut contains one bolt with an NSD pressure cartridge at each end. The upper strut also carries the umbilical interface between its SRB and the external tank and on to the orbiter.

There are four booster separation motors on each end of each SRB. The BSMs separate the SRBs from the external tank. The solid rocket motors in each cluster of four are ignited by

firing redundant NSD pressure cartridges into redundant confined detonating fuse manifolds.

The separation commands issued from the orbiter by the SRB separation sequence initiate the redundant NSD pressure cartridge in each bolt and ignite the BSMs to effect a clean separation.

SPACE SHUTTLE SUPER LIGHT WEIGHT TANK (SLWT)

The super lightweight external tank (SLWT) made its first Shuttle flight June 2, 1998, on mission STS-91. The SLWT is 7,500 pounds lighter than the standard external tank. The lighter weight tank allows the Shuttle to deliver International Space Station elements (such as the service module) into the proper orbit.

The SLWT is the same size as the previous design. But the liquid hydrogen tank and the liquid oxygen tank are made of aluminum lithium, a lighter, stronger material than the metal alloy used for the Shuttle's current tank. The tank's structural design has also been improved, making it 30 percent stronger and 5 percent less dense.

The SLWT, like the standard tank, is manufactured at Michoud Assembly, near New Orleans, by Lockheed Martin.

The 154-foot-long external tank is the largest single component of the Space Shuttle. It stands taller than a 15-story building and has a diameter of about 27 feet. The external tank holds over 530,000 gallons of liquid hydrogen and liquid oxygen in two separate tanks. The hydrogen (fuel) and liquid oxygen (oxidizer) are used as propellants for the Shuttle's three main engines.

ACRONYMS AND ABBREVIATIONS

A/L	Airlock
AA	Antenna Assembly
AAA	Avionics Air Assembly
ABC	Audio Bus Coupler
AC	Assembly Complete
ACBM	Active Common Berthing System
ACS	Assembly Contingency System
ACS	Atmosphere Control and Supply
ACS	Attitude Control System
ACSM	Attitude Control System Moding
ACU	Arm Computer Unit
AEA	Antenna Electronics Assembly
AOH	Assembly Operations Handbook
APAS	Androgynous Peripheral Attach System
APAS	Androgynous Peripheral Attachment System
APCU	Assembly Power Converter Unit
APDS	Androgynous Peripheral Docking System
APFR	Articulating Portable Foot Restraint
APM	Attached Pressurized Module
APPCM	Arm Pitch Plane Change Mode
AR	Atmosphere Revitalization
ARCU	American-to-Russian Converter Units
ARIS	Active Rack Isolation System
ARS	Air Revitalization System
ARS	Atmosphere Revitalization Subsystem
ASCR	Assured Safe Crew Return
ATA	Ammonia Tank Assembly
ATCS	Active Thermal Control System
ATU	Audio Terminal units
AUAI	Assembly Contingency System/UHF Audio Interface
AVU	Advanced Vision Unit
AVU	Artificial Vision Unit
AVV	Accumulator Vent Valve
BBC	Bolt Bus Controller
BC	Bus Controller
BCDU	Battery Charge/Discharge Unit
BCU	Bus Controller Unit
BDU	Backup Drive Unit
BG	Beta Gimbal
BGA	Beta Gimbal Assembly
BGDTS	Beta Gimbal Deployment Transition Structure
BGHS	Beta Gimbal Housing Subassembly

BIT/BITE	Built-In Test/Built-In Test Equipment
BMRRM	Bearing Motor and Roll Ring Module
BSP	Baseband Signal Processor
C&C	Command and Control
C&DH	Command and Data Handling
C&M	Control and Monitor
C&T	Communications and Tracking
C&W	Caution and Warning
C/A	Coarse/Acquisition
C/L	Crew Lock
CA	Control Attitude
CAS	Common Attach System
CBM	Common Berthing Mechanism
CCAA	Common Cabin Air Assembly
CCD	Cursor Control Device
CCMS	Concentric Cable Management System
CCTV	Closed Circuit TV
CDRA	Carbon Dioxide Removal Assembly
CDRS	Carbon Dioxide Removal System
CDS	Command and Data Software
CETA	Crew and Equipment Translation Aid
CEU	Control Electronics Unit
CGBA	Commercial Generic Bioprocessing Apparatus
CheCS	Crew Health Care System
CHX	Condensing Heat Exchanger
CMG	Control Moment Gyroscopes
COAS	Crew Optical Alignment Sight
COTS	Commercial Off The Shelf
CR	Change Request
CSA	Canadian Space Agency
CSA	Computer Systems Architecture
CSCI	Computer Software Configuration Item
CVIU	Common Video Interface Unit
CVT	Current Value Table
CVV	Carbon dioxide Vent Valve
CWC	Contingency Water Collection
CWC	Contingency Water Container
DAIU	Docked Audio Interface Unit
DC	Docking Compartment
DCP	Display and Control Panel
DCSU	Direct Current Switching Unit
DDCU	DC-to-DC Converter Unit
DDCU-E	DC-to-DC Converter Unit - External
DDCU-I	DC-to-DC Converter - Internal
DLA	Drive Locking Assembly

DMS-R	Data Management System-Russian
DPA	Digital Pre-Assembly
DPS	Data Processing System
DSO	Detailed Supplementary Objective
DTO	Detailed Test Objective
E/L	Equipment Lock
EACP	EMU Audio Control Panel
EACP	EV Audio Control Panel
EAIU	EMU Audio Interface Unit
EATCS	External Active Thermal Control Subsystem
ECLSS	Environmental Control and Life Support System
ECU	Electronic Control Unit
ED	Engagement Drive
EDDA	EMU Don/Doff Assembly
EEATCS	Early External Active Thermal Control Subsystem
EFGF	Electrical Flight Grapple Fixture
EIA	Electrical Interface Assembly
EMU	Extravehicular Mobility Unit
EPS	Electrical Power System
ESA	External Sampling Adapter
ESP	External Stowage Platform
ESPAD	External Stowage Platform Attachment Device
ESSMDM	Enhanced Space Station Multiplexer/Demultiplexer
ESU	End Stop Unit
ETVCG	Pg 3-4
EUTAS	Enhanced Universal Truss Attachment System
EVA	Extra Vehicular Activity
EV-CPDS	Extra-Vehicular - Charged Particle Directional Spectrometer
EVR	Extravehicular Robotics
EVSU	External Video Switching Units
EWA	Emittance Wash Applicator
EXPRESS	EXpedite the PROcessing of Experiments to the Space Station
EXT	External
FC	Firmware Controller
FCC	Flat Collector Circuit
FCV	Flow Control Valve
FD	Flight Day
FDIR	Failure, Detection, Isolation, and Recovery
FDS	Fire Detection Suppression
FET	Field Effect Transistors
FGB	Functional Cargo Block
FPU	Fluid Pumping Unit
FQDC	Fluid Quick Disconnect Coupling
FRD	Flight Requirements Document
FRGF	Flight Releasable Grapple Feature

FWCI	Firmware Configuration Items
GFE	Government Furnished Equipment
GFI	Ground Fault Interrupter
GLONASS	Global Navigational Satellite System
GNC	Guidance, Navigation, and Control
GPS	Global Positioning System
GUI	Graphical User Interface
HC	Hand Controller
HCA	Hollow Cathode Assembly
HDR	High Data Rate
HEPA	High Efficiency Particulate Air
HGA	High Gain Antenna
HHL	Hand Held Lidar
HPGT	High Pressure Gas Tank
HRF	Human Research Facility
HRFM	High Rate Frame Multiplexer
HRM	High Rate Modem
I/O	Input/Output
IAC	Internal Audio Controller
IAS	Internal Audio Subsystem
IAS	Internal Audio System
IATCS	Internal Active Thermal Control Subsystem
IATCS	Internal Active Thermal Control System
IDA	Integrated Diode Assembly
IDRD	Increment Definition and Requirements Document
IEA	Integrated Equipment Assembly
IELK	Individual Equipment Liner Kit
IFHX	Interface Heat Exchanger
IMCS	Integrated Mission Control System
IMV	Intermodule Ventilation
INT	Internal
IOC	Input/Output Controller
IOCU	Input/Output Controller Unit
IP	International Partner
IRU	Inflight Refill Unit
ISA	Internal Sampling Adapter
ISPR	International Standard Payload Racks
ISS	International Space Station
ISSPO	International Space Station Program Office
ISSSH	International Space Station Systems Handbook
ITCS	Internal Thermal Control System
ITS	Integrated Truss Structure
IUA	Interface Umbilical Assembly
IVA	Intra-Vehicular Activity

IVSU	Internal Video Switch Unit
JEU	Joint Electronic Units
Lab	Laboratory
LAN	Local Area Network
LCA	Lab Cradle Assembly
LCA	Loop Crossover Assembly
LCD	Liquid Crystal Display
LDI	Local Data Interface
LDR	Low Data Rate
LDU	Linear Drive Unit
LED	Light Emitting Diode
LEE	Latching End Effector
LFDP	Load Fault Detect Protect
LFDP	Load Fault Detection Protection
LGA	Low Gain Antenna
LLA	Low Level Analog
LMC	Lightweight Mission Peculiar Equipment Support Structure Carrier
LT	Low Temperature
LTA	Launch-To-Activation
LTL	Low Temperature Loop
LTU	Load Transfer Unit
LVLH	Local Vertical Local Horizontal
MA	Mechanical Assembly
MAM	Manual Augmented Mode
MBM	Manual Berthing Mechanism
MBS	Mobile remote servicer Base System
MBSU	Main Bus Switching Units
MC	Midcourse Correction
MCA	Major Constituent Analyzer
MCAS	MBS Common Attach System
MCC	Mission Control Center
MCC-H	Mission Control Center-Houston
MCC-M	Mission Control Center-Moscow
MCDS	Multifunction Cathode Ray Tube Display System
MCS	Motion Control System
MCU	MBS Computer Unit
MDM	Multiplexer/Demultiplexer
METOX	Metal Oxide
MFCV	Manual Flow Control Valve
MFSC	Marshall Spaceflight Center
MHS	MCU Host Software
MIP	Mission Integration Plan
MISSE	Materials International Space Station Experiment
MLI	Multi-Layer Insulation

MMT	Mission Management Team
MPES	Lightweight Multi-Purpose External Support Structure
MPEV	Manual Pressure Equalization Valve
MPLM	Multi-Purpose Logistics Module
MPM	Manipulator Positioning Mechanism
MRL	Manipulator Retention Latch
MRS	Mobile Remote Servicer
MSD	Mass Storage Device
MSG	Microgravity Science Glovebox
MSS	Mobile Servicing System
MT	Mobile Transporter
MT	Moderate Temperature
MTCL	MT Capture Latch
MTL	Moderate Temperature Loop
MTS	Module to Truss Segment
MTSAS	Module to Truss Segment Attachment System
MTWsN	Move To Worksite number N
NASA	National Aeronautics and Space Administration
NCC	Nominal Corrective Combination
NCG	Non-Condensable Gas
NET	No Earlier
NIA	Nitrogen Interface Assembly
NIV	Nitrogen Isolation Valve
NTA	Nitrogen Tank Assembly
NOAX	Non-Oxide Adhesive Experimental
OBSS	Orbiter Boom Sensor System
OCA	Orbital Communications Adapter
OCJM	Operator Commanded Joint Position Mode
OCPM	Operator Commanded POR Mode
OCS	Operations and Control Software
ODS	Orbiter Docking System
OIU	Orbiter Interface Unit
OIV	Oxygen Isolation Valve
OMI	On-Orbit Maintainable Items
OMS	Orbital Maneuvering System
OPP	OSVS Patch Panel
OPS	Operations
Ops	Operations
ORBT	Optimized RBar Targeting
ORCA	Oxygen Recharge Compressor Assembly
ORU	Orbital Replacement Units
OSVS	Orbiter Space Vision System
OTD	ORU Transfer Device
P&S	Pointing and Support

P/L	Payload
P1	Port 1
PAS	Payload Attach System
PBA	Portable Breathing Apparatus
PC	Personal Computer
PCA	Pressure Control Assembly
PCBM	Passive Common Berthing System
PCC	Power Converter Controller
PCG	Protein Crystal Growth
PCMCIA	Personal Computer Memory Card International Adapter
P-Code	Precision Code
PCP	Pressure Control Panel
PCR	Portable Computer Receptacle
PCS	Portable Computer System
PCT	Post-Contact Thrusting
PCU	Plasma Contactor Unit
PDGF	Power and Data Grapple Fixture
PDIP	Payload Data Interface Panel
PDRS	Payload Deployment and Retrieval System
PDU	Power Drive Unit
PEHG	Payload Ethernet Hub Gateways
PFCS	Pump and Flow Control Subassembly
PFE	Portable Fire Extinguisher
PGBA	Plant Generic Bioprocessing Apparatus
PGSC	Portable General Support Computer
PGT	Pistol Grip Tool
PJAM	Prestored Joint Position Autosequence Mode
PM	Pump Module
PMCU	Power Management Control Unit
POA	Payload/ORU Accommodation
POR	Points of Reference
POST	Power On Self-Test
PP	Planning Period
PPA	Pump Package Assembly
PPAM	Prestored POR Autosequence Mode
PPRV	Positive Pressure Relief Valve
PRLA	Payload Retention Latch Assemblies
Prox-Ops	Proximity Operations
PRPV	Positive Pressure Release Valves
PTCS	Passive Thermal Control System
PTU	Pan/Tilt Unit
PVCA	Photovoltaic Controller Application
PVCE	Photovoltaic Controller Element
PVM	Photovoltaic Module
PVR	Photovoltaic Radiator
PVTCs	Photovoltaic Thermal Control System

PWR	Payload Water Reservoir
QD	Quick Disconnect
RCG	Reaction-Cured Glass
R/P	Receiver/Processors
RACU	Russian-to-American Converter Units
RAIU	Russian Audio Interface Unit
RAM	Random Access Memory
RAMV	Rheostat Air Mix Valve
RBI	Remote Bus Isolators
RBVM	Radiator Beam Valve Module
RF	Radio Frequency
RFCA	Rack Flow Control Assembly
RFG	Radio Frequency Group
RGA	Rate Gyros Assembly
RHC	Rotational Hand Controller
RHX	Regenerative Heat Exchanger
RJMC	Rotary Joint Motor Controller
RMS	Remote Manipulator System
RPC	Remote Power Controller
RPCM	Remote Power Controller Module
RPDA	Remote Power Distribution Assembly
RPOP	Rendezvous and Prox-Ops Program
RS	Russian Segment
RSP	Resupply Stowage Platforms
RSR	Resupply Stowage Rack
RSTS	Rack Standalone Temperature Sensor
RSU	Roller Suspension Unit
RT	Remote Terminal
RTD	Resistive Thermal Devices
RTV	Room Temperature Vulcanizing
RWS	Robotic Workstation
S&M	Structures and Mechanisms
SARJ	Solar Alpha Rotary Joint
SASA	S-band Antenna Support Assembly
SAW	Solar Array Wing
SCA	Switchgear Controller Assembly
SCI	Signal Conditioning Interface
SCU	Service and Cooling Umbilical
SCU	Sync and Control Unit
SD	Smoke Detector
SDO	Solenoid Driver Output
SDS	Sample Delivery System
SEM	Shunt Electronics Module
SFCA	System Flow Control Assembly

SFU	Squib Firing Unit
SGANT	Space-to-Ground Antenna
SiC	Silicon Carbide
SIGI	Space Integrated Global Positioning System/Inertial Navigation
System	
SJRM	Single Joint Rate Mode
SM	Service Module
SMCC	Shuttle Mission Control Center
SOC	State of Charge
SPCE	Servicing Performance and Checkout Equipment
SPDA	Secondary Power Distribution Assembly
SPDM	Special Purpose Dexterous Manipulator
SPG	Single Point Ground
SRMS	Shuttle Remote Manipulator System
SSAS	Segment-to-Segment Attach System
SSC	Station Support Computer
SSC	Subsystem Computer
SSMDM	Space Station Multiplexer/Demultiplexer
SSOR	Space-to-Space Orbiter Radio
SSP	Space Shuttle Program
SSP	Standard Switch Panel
SSRMS	Space Station Remote Manipulator System
SSSR	Space-to-Space Station Radio
SSU	Sequential Shunt Unit
STCR	Starboard Thermal Control Radiator
STES	Single Locker Thermal Enclosure
STS	Space Transportation System
SVS	Synthetic Vision System
TA	Thruster Assist
TBD	To Be Determined
TC	Terminal Computers
TCCS	Trace Contaminant Control Subassembly
TCCV	Temperature Check Control Valve
TCS	Thermal Control System
TCS	Trajectory Control Sensor
TCTV	Temperature Control and Check Valve
TD	Translation Drive
TDRS	Tracking and Data Relay Satellite
TDRSS	Tracking and Data Relay Satellite System
TEA	Torque Equilibrium Attitude
TFR	Translation Foot Restraints
THC	Temperature and Humidity Control
THC	Translational Hand Controller
TI	Transition Initiation
TORU	Teleoperator Control Mode

TORVA	Twice Orbital rate +Rbar to +Vbar Approach
TRC	Transmitter Receiver Controller
TRRJ	Thermal Radiator Rotary Joint
TSP	Twisted Shielded Pairs
TTCR	Trailing Thermal Control Radiator
TUS	Training Umbilical System
TV	Television
TVIS	Treadmill Vibration Isolation System
TWMV	Three-Way Mixing Valve
UDG	User Data Generation
UHF	Ultra-High Frequency
UIA	Umbilical Interface Assembly
UIP	Utility Interface Panel
ULCAS	Unpressurized Logistics Carrier Attach System
UMA	Umbilical Mechanism Assembly
UOP	Utility Outlet Panel
USOS	United States Orbital Segment
VAJ	Vacuum Access Jumper
VBSP	Video Baseband Signal Processor
VCP	Video Camera Port
VCSA	Video Camera Support Assembly
VDS	Video Distribution Subsystem
VDS	Video Distribution System
VDU	Video Distribution Unit
VES	Vacuum Exhaust System
VGS	Video Graphics Software
VRCV	Vent/Relief Control Valve
VRIV	Vent/Relief Isolation Valve
VRS	Vacuum Resource System
VRV	Vent/Relief Valve
VSC	Video Signal Converter
VTR	Video Tape Recorders
WETA	Wireless video system External Transceiver Assemblies
WHS	Workstation Host Software
WLE	Wing Leading Edge
WRM	Water Recovery and Management
WS	Water Separator
WVA	Water Vent Assembly
ZSR	Zero-g Stowage Rack

MEDIA ASSISTANCE

NASA TELEVISION TRANSMISSION

NASA Television can be seen in the continental United States on AMC-6, at 72 degrees west longitude, Transponder 9, 3880 MHz, vertical polarization, audio at 6.8 MHz. If you live in Alaska or Hawaii, NASA TV can now be seen on AMC-7, at 137 degrees west longitude, Transponder 18, at 4060 MHz, vertical polarization, audio at 6.8 MHz.

The schedule for television transmissions from the orbiter and for mission briefings will be available during the mission at Kennedy Space Center, Fla.; Marshall Space Flight Center, Huntsville, Ala.; Dryden Flight Research Center, Edwards, Calif.; Johnson Space Center, Houston, Texas; and NASA Headquarters, Washington, DC. The television schedule will be updated to reflect changes dictated by mission operations.

Status Reports

Status reports on countdown and mission progress, on-orbit activities and landing operations will be produced by the appropriate NASA news center.

Briefings

A mission press briefing schedule will be issued before launch. During the mission, status briefings by a flight director or mission operations representative and Mission Management Team members will occur every day. The updated NASA television schedule will indicate when mission briefings are planned.

Internet Information

Information is available through several sources on the Internet. The primary source for mission information is the NASA Web, part of the World Wide Web. This site contains information on the crew and its mission and will be updated regularly with status reports, photos and video clips throughout the flight. The NASA Web's address is:

<http://www.nasa.gov/>

Information on other current NASA activities is available through the Today@NASA page:

<http://www.nasa.gov/news/highlights/>

The NASA TV schedule is available from the NTV Home Page:

http://www.nasa.gov/multimedia/nasatv/MM_NTV_Breaking.html

Resources for educators can be found at the following address:

<http://education.nasa.gov>



PUBLIC AFFAIRS CONTACTS

HEADQUARTERS - WASHINGTON, DC

Allard Beutel
Public Affairs Officer
Space Operations
202-358-4769

Melissa Mathews
Public Affairs Officer
Space Operations
202-358-1272

Katherine Trinidad
Public Affairs Officer
Space Operations
202-358-3749

Debbie Rahn
Public Affairs Officer
International Partners
202-358-1638

KENNEDY SPACE CENTER FLORIDA

Bruce Buckingham
News Chief
321-861-7642

Jessica Rye
Public Affairs Specialist
Space Shuttle
321-867-2468

Tracy Young
Public Affairs Specialist
International Space Station
321-867-9284

JOHNSON SPACE CENTER HOUSTON, TX

James Hartsfield
News Chief
281-483-5111

Kyle Herring
Public Affairs Specialist
Space Shuttle Program Office
281-483-5111

Kylie Clem
Public Affairs Specialist
International Space Station Program Office
281-483-5111

Kelly Humphries
Public Affairs Specialist
Mission Operations & Engineering
281-483-5111

Rob Navias
Program and Mission Operations Lead
281-483-5111

MARSHALL SPACE FLIGHT CENTER HUNTSVILLE, AL

Dom Amatore
Public Affairs Manager
256-544-0034

June Malone
Public Affairs Specialist
Space Shuttle Propulsion
256-544-0034



**STENNIS SPACE CENTER
BAY ST. LOUIS, MS**

Linda Theobald
Public Affairs Officer
228-688-3249

Paul Foerman
News Chief
228-688-1880

Rebecca Strecker
Public Affairs Specialist
Office: 228-688-3346

**AMES RESEARCH CENTER
MOFFETT FIELD, CA**

Mike Mewhinney
News Chief
650-604-3937

Jonas Dino
Public Affairs Specialist
650-604-5612

**DRYDEN FLIGHT RESEARCH CENTER
CALIFORNIA**

Alan Brown
News Chief
661-276-2665

Leslie Williams
Public Affairs Specialist
661-276-3893

**GLENN RESEARCH CENTER
CLEVELAND, OH**

Lori Rachul
News Chief
216-433-8806

Katherine Martin
Public Affairs Specialist
216-433-2406

**LANGLEY RESEARCH CENTER
HAMPTON, VA**

H. Keith Henry
Deputy, Office of Public Affairs
757-864-6120

UNITED SPACE ALLIANCE

Mike Curie
Space Flight Operations Contract
281-483-9251
321-861-3805

Kari Fluegel
Houston Operations
281-280-6959

Tracy Yates
Florida Operations
321-861-3956

BOEING

Ed Memi
Media Relations
Boeing NASA Systems
281-226-4029

